17-inch PowerBook G4 Developer Note

[Hardware & Drivers](#) > [Apple Hardware](#)



2005-10-19



Apple Inc.
© 2003, 2005 Apple Computer, Inc.
All rights reserved.

No part of this publication may be reproduced, stored in a retrieval system, or transmitted, in any form or by any means, mechanical, electronic, photocopying, recording, or otherwise, without prior written permission of Apple Inc., with the following exceptions: Any person is hereby authorized to store documentation on a single computer for personal use only and to print copies of documentation for personal use provided that the documentation contains Apple's copyright notice.

The Apple logo is a trademark of Apple Inc.

Use of the "keyboard" Apple logo (Option-Shift-K) for commercial purposes without the prior written consent of Apple may constitute trademark infringement and unfair competition in violation of federal and state laws.

No licenses, express or implied, are granted with respect to any of the technology described in this document. Apple retains all intellectual property rights associated with the technology described in this document. This document is intended to assist application developers to develop applications only for Apple-labeled computers.

Every effort has been made to ensure that the information in this document is accurate. Apple is not responsible for typographical errors.

Apple Inc.
1 Infinite Loop
Cupertino, CA 95014
408-996-1010

Apple, the Apple logo, AirPort, AirPort Extreme, Carbon, FireWire, iChat, iPod, iSight, Mac, Mac OS, Macintosh, PowerBook, QuickTime, SuperDrive, and Velocity Engine are trademarks of Apple Inc., registered in the United States and other countries.

DEC is a trademark of Digital Equipment Corporation.

Intel and Intel Core are registered trademarks of Intel Corporation or its subsidiaries in the United States and other countries.

Mighty Mouse is a registered trademark of CBS Opertaions, Inc.

OpenGL is a registered trademark of Silicon Graphics, Inc.

PowerPC and the PowerPC logo are trademarks of International Business Machines Corporation, used under license therefrom.

Simultaneously published in the United States and Canada.

Even though Apple has reviewed this document, APPLE MAKES NO WARRANTY OR REPRESENTATION, EITHER EXPRESS OR IMPLIED, WITH RESPECT TO THIS DOCUMENT, ITS QUALITY, ACCURACY, MERCHANTABILITY, OR FITNESS FOR A PARTICULAR PURPOSE. AS A RESULT, THIS DOCUMENT IS PROVIDED "AS IS," AND YOU, THE READER, ARE ASSUMING THE ENTIRE RISK AS TO ITS QUALITY AND ACCURACY.

IN NO EVENT WILL APPLE BE LIABLE FOR DIRECT, INDIRECT, SPECIAL, INCIDENTAL, OR CONSEQUENTIAL DAMAGES RESULTING FROM ANY DEFECT OR INACCURACY IN THIS DOCUMENT, even if advised of the possibility of such damages.

THE WARRANTY AND REMEDIES SET FORTH ABOVE ARE EXCLUSIVE AND IN LIEU OF ALL OTHERS, ORAL OR WRITTEN, EXPRESS OR IMPLIED. No Apple dealer, agent, or employee is authorized to make any modification, extension, or addition to this warranty.

Some states do not allow the exclusion or limitation of implied warranties or liability for incidental or consequential damages, so the above limitation or exclusion may not apply to you. This warranty gives you specific legal rights, and you may also have other rights which vary from state to state.

Contents

Introduction **Introduction to 17-inch PowerBook G4 Developer Note** 9

Organization of This Document 9

Chapter 1 **Overview of 17-inch PowerBook G4** 11

New Features 11
All Features 12
Appearance 14
Peripheral Devices 15
System Software 16
 Open Firmware 16
 Computer Identification 16
 Power Management 16

Chapter 2 **Architecture** 19

Block Diagram and Buses 19
 Block Diagram 19
 Main IC and Buses 20
Microprocessor and Caches 21
 PowerPC G4 Microprocessor 21
 Level 2 Cache 21
Intrepid 2 Controller Functions and Buses 21
 System RAM 22
 Boot ROM 22
 FireWire Controllers 22
 Ethernet Controller 23
 Video Display Subsystem 23
 DMA Support 24
 Interrupt Support 24
 USB Interface 24
 Ultra DMA ATA-100 Interface 24
 Modem Support 24
 Audio Circuitry 24
 Power Controller 25
 Sudden Motion Sensor 26
AirPort Extreme and Bluetooth Module 26
PC Card/CardBus Controller IC 26
PCI USB 2.0 Controller 26

Chapter 3 Devices and Ports 27

- USB 2.0 Ports 27
 - USB Connectors 27
 - USB Class Drivers 28
- FireWire Ports 28
 - FireWire 400 Connector 28
 - FireWire 800 Connector 29
 - FireWire Device Programming 31
 - Target Disk Mode 31
- Ethernet Port 32
- Internal Modem 33
- AirPort Extreme 33
 - Data Security 34
 - AirPort Extreme Hardware 34
 - AirPort Extreme Software 34
- Bluetooth 2.0 with EDR 35
- Hard Disk Drive 35
 - Hard Disk Dimensions 36
 - Hard Disk Connector 36
- SuperDrive 39
- Combo Drive 40
- Trackpad 41
- Keyboard 41
 - Changing the Operation of the Keyboard 41
- Flat-Panel Display 47
- External Monitors 48
 - Dual Display and Mirror Mode 48
 - Analog Monitor Resolutions 49
 - Digital Display Resolutions 49
 - DVI-I Connector 50
- External Video Port 51
- Audio System 53
 - Optical Digital Audio 53
 - Audio Inputs 54
 - Audio Outputs 55
 - Digitizing Audio 56

Chapter 4 Expansion Features 57

- RAM Expansion Slots 57
 - Accessing the RAM Slots 57
 - Mechanical Design of DDR2 RAM SO-DIMMs 58
 - Electrical Design of DDR2 RAM SO-DIMMs 58
 - RAM SO-DIMM Electrical Limits 60
- PC Card/CardBus Slot 60

Appendix A **Supplemental Reference Documents 61**

- Apple Technical Notes 61
- 3D Graphics 61
- PowerPC G4 Microprocessor 61
- Velocity Engine 62
- Mac OS X 62
- IOKit 62
- Open Firmware 62
- RAM Expansion Modules 63
- ATA Devices 63
- USB Interface 63
- FireWire Interface 64
- Digital Visual Interface 64
- Wireless Networks 64
- Bluetooth 64

Appendix B **Abbreviations 67**

- Abbreviations and Standard Units 67
- Other Abbreviations 67

Index 71

Figures and Tables

Chapter 1 Overview of 17-inch PowerBook G4 11

Figure 1-1	Front view of the computer	14
Figure 1-2	Side views showing I/O ports	15
Table 1-1	Main Feature comparison	11

Chapter 2 Architecture 19

Figure 2-1	Block diagram	20
Table 2-1	Buses supported by the Intrepid 2 IC with DDR2 RAM	22

Chapter 3 Devices and Ports 27

Figure 3-1	USB Type A port	27
Figure 3-2	6-pin FireWire connector	29
Figure 3-3	9-pin FireWire 800 connector	30
Figure 3-4	Maximum dimensions of the internal hard disk	36
Figure 3-5	Hard disk connector and location	37
Figure 3-6	Keyboard layout	42
Figure 3-7	Alternate operations of function and control keys	43
Figure 3-8	Embedded numeric keypad operation	44
Figure 3-9	DVI-I connector	50
Figure 3-10	S-video connector	52
Table 3-1	Pin assignments on the USB port	27
Table 3-2	Pin assignments on the 6-pin FireWire connector	29
Table 3-3	Signals on the 9-pin FireWire 800 connector	30
Table 3-4	Signals for 10BASE-T and 100BASE-T operation	32
Table 3-5	Signals for 1000BASE-T operation	32
Table 3-6	Pin assignments on the ATA hard disk connector	37
Table 3-7	Signals on the ATA hard disk connector	38
Table 3-8	Media read and written by the SuperDrive	39
Table 3-9	Types of media read and written by the Combo drive	40
Table 3-10	The function keys as control buttons	45
Table 3-11	Embedded keypad keys	46
Table 3-12	Control keys that change	46
Table 3-13	Picture sizes on the flat-panel display	47
Table 3-14	Picture sizes on an analog monitor	49
Table 3-15	Picture sizes on a digital display	49
Table 3-16	Main signals on the DVI-I connector	50
Table 3-17	MicroCross signals on the DVI-I connector	51
Table 3-18	Pin assignments for the S-video output connector	52
Table 3-19	Picture sizes for S-video output	52

Chapter 4 **Expansion Features** **57**

Figure 4-1	Removing RAM expansion slot cover	57
Table 4-1	Sizes of DDR2 SDRAM expansion SO-DIMMS and devices	59
Table 4-2	Types of DDR2 SDRAM devices	60

Introduction to 17-inch PowerBook G4 Developer Note

This developer note is a technical description of the 17-inch PowerBook G4. The note provides information about the computer's internal design, input-output features, and expansion capabilities.

This developer note is intended to help hardware and software developers design products that are compatible with the Macintosh products described here. If you are not already familiar with Macintosh computers or if you would like additional technical information, you may wish to read the supplementary reference documents described in "[Supplemental Reference Documents](#)" (page 61).

Organization of This Document

The information in this note is arranged in four chapters and two appendixes.

- "[Overview of 17-inch PowerBook G4](#)" (page 11) introduces the 17-inch PowerBook G4 and describes its features.
- "[Architecture](#)" (page 19) describes the internal logic of the computer, including the main ICs that appear in the block diagram.
- "[Devices and Ports](#)" (page 27) describes the standard I/O ports and the built-in I/O devices.
- "[Expansion Features](#)" (page 57) describes the expansion features of interest to developers. It includes development guides for expansion-bay devices, the RAM expansion modules, and the PC Card slot.
- "[Supplemental Reference Documents](#)" (page 61) contains links to supplemental reference documents.
- "[Abbreviations](#)" (page 67) is a list of the abbreviations used in this developer note.

INTRODUCTION

Introduction to 17-inch PowerBook G4 Developer Note

Overview of 17-inch PowerBook G4

This chapter outlines the features of the 17-inch PowerBook G4, with emphasis on the changes from the previous model.

New Features

Below is a list of the features that are new to the 17-inch PowerBook G4. For a quick summary of the main feature comparison of new and previous models, see [Table 1-1](#) (page 11). Each feature is described in a later chapter, as indicated.

- **Hard disk storage:** The computer comes with a built-in 5400 rpm hard disk drive with a capacity of 120 GB. A 100 GB 7200 rpm disk drive is available as a build-to-order option. For more information, see "[Hard Disk Drive](#)" (page 35).
- **Graphics IC and memory:** The ATI Mobility Radeon 9700 graphics controller operates on the AGP-4x bus with 128 MB of video RAM and dual link DVI functionality. For more information, see "[Video Display Subsystem](#)" (page 23).
- **Optical drive:** The computer has an 8x SuperDrive with double layer burning capability. A Combo drive is available as a build-to-order option. For more information, see "[SuperDrive](#)" (page 39) or "[Combo Drive](#)" (page 40).
- **Display:** The display is a 116 dpi, 17 inch wide-screen, active matrix TFT with a resolution of 1680x1050. See "[Flat-Panel Display](#)" (page 47).
- **RAM:** The computer has two standard PC2-4200 DDR2 SO-DIMM expansion slots for SDRAM modules. See "[RAM Expansion Slots](#)" (page 57).

Table 1-1 Main Feature comparison

Feature	Previous model	Current model
Processor	PowerPC G4	
Enclosure	aluminum alloy	
Processor clock speed	1.67 GHz	
Graphics IC	ATI Mobility Radeon 9700	
System bus speed	167 MHz	
Device ports	2 USB 2.0; 1 FireWire 400 ; 1 FireWire 800	
Graphics memory	128 MB of DDR and dual link DVI	

Feature	Previous model	Current model
Hard disk drive	100 GB 5400 rpm	120 GB 5400 rpm. BTO: 100 GB 7200 rpm
Keyboard	Backlit keyboard and ambient light sensors.	
RAM	512 MB PC2700 DDR SDRAM SO-DIMMs running at 333 MHz with 2 GB expansion capacity	512 MB PC2-4200 DDR2 SDRAM SO-DIMMs running at 333 MHz with 2 GB expansion capacity
Wireless	AirPort Extreme and fully-integrated Bluetooth 2.0 + EDR	AirPort Extreme and Bluetooth 2.0 +EDR combined into a single module
Battery	58 watt-hours battery	
Power adapter	65 W power adapter	
Removable media	8x SuperDrive	double-layer burning 8x SuperDrive
Audio	combined audio line-in and optical digital audio input port and combined headphone output and optical digital audio output port	

All Features

Here is a list of all features of the 17-inch PowerBook G4. Each feature is described in a later chapter, as indicated.

- **Processor:** The computer has a PowerPC G4 microprocessor running at a clock speed of 1.67 GHz. For more information, see "[PowerPC G4 Microprocessor](#)" (page 21).
- **System bus:** The speed of the system bus is 167 MHz.
- **L2 cache:** The L2 cache has a capacity of 512 KB; see "[Level 2 Cache](#)" (page 21).
- **RAM:** The computer has two SO-DIMM expansion slots for PC2-4200 DDR2 SDRAM modules running at 333 MHz. The computer comes with 512 MB of SDRAM installed in one slot. Available as build to order options are two 512 MB or two 1 GB SO-DIMMs. Maximum RAM is 2 GB. See "[RAM Expansion Slots](#)" (page 57).
- **ROM:** The computer has 1 MB of boot ROM used by Open Firmware at startup. For information about the ROM, see "[Boot ROM](#)" (page 22). For information about Open Firmware, see "[Open Firmware](#)" (page 62).
- **Hard disk storage:** The computer comes with a built-in 5400 rpm hard disk drive with a capacity of 120 GB. A 100 GB 7200 rpm disk drive is available as a build-to-order option. For more information, see "[Hard Disk Drive](#)" (page 35).
- **Display:** The display is a 116 dpi, 17 inch wide-screen, active matrix, TFT with a resolution of 1680x1050. See "[Flat-Panel Display](#)" (page 47).
- **External monitor:** The computer supports an external video monitor, using the DVI connector for a digital video display and an S-video connector for a PAL or NTSC video monitor. Included with the computer are a DVI-to-VGA adapter and an S-video-to-composite adapter; a DVI-to-ADC Apple Display Connector adapter is available separately. See "[External Monitors](#)" (page 48).

- **Graphics IC and memory:** The ATI Mobility Radeon 9700 graphics controller operates on the AGP-4x bus with 128 MB of video RAM with dual link DVI functionality. For more information, see "[Video Display Subsystem](#)" (page 23).
- **Battery bay:** The computer has a single battery bay. The battery uses lithium ion cells and provides 58 watt-hours at 10.8 V (nominal) for up to 5.5 hours.
- **Power adapter:** The computer comes with a 65 W power adapter with safety ground. For more information, see "[Power Controller](#)" (page 25).
- **Optical drive:** The computer has an 8x SuperDrive with double layer burning capability. A Combo drive is available as a build-to-order option. For more information, see "[SuperDrive](#)" (page 39) or "[Combo Drive](#)" (page 40).
- **PC Card/CardBus slot:** The computer has a PC Card/CardBus slot that accepts one Type I or Type II PC Card or a CardBus Card. For more information, see "[PC Card/CardBus Slot](#)" (page 60).
- **USB 2.0 ports:** The computer has two USB 2.0 ports for an external keyboard, a mouse, and other USB devices, described in "[USB 2.0 Ports](#)" (page 27).
- **FireWire ports:** The computer has one IEEE-1394a 400 Mbps serial FireWire 400 port and one IEEE-1394b 800 Mbps serial FireWire 800 port. For more information, see "[FireWire Ports](#)" (page 28).
- **Target disk mode:** The 17-inch PowerBook G4 can act like a FireWire storage device connected to another computer. See "[Target Disk Mode](#)" (page 31).
- **Modem:** The computer has a built-in modem with 56 Kbps data rate and V.34, V.90, and V.92 support. For more information, see "[Internal Modem](#)" (page 33).
- **Ethernet:** The computer has a built in Ethernet port with an RJ-45 connector for 10BASE-T, 100BASE-T, and 1000BASE-T operation. For more information, see "[Ethernet Port](#)" (page 32).
- **AirPort Extreme/Bluetooth module:** A combined, internal AirPort Extreme wireless LAN and Bluetooth module is standard on the 17-inch PowerBook G4 computer. For more information, see "[AirPort Extreme and Bluetooth Module](#)" (page 26).
- **Dual Link TMDS:** The computer provides dual link DVI functionality. For more information, see "[Video Display Subsystem](#)" (page 23).
- **Audio:** The computer has a combined audio line-in and optical digital audio input port, and a combined headphone output and optical digital audio output port. For more information, see "[Audio System](#)" (page 53).
- **Sudden Motion Sensor:** Helps protect the hard drive from sudden drops or falls by parking the hard drive when sudden changes in position and accelerated movement are detected. For more information, see "[Sudden Motion Sensor](#)" (page 26).
- **Illuminated keyboard:** The computer has a backlit keyboard for optimal usability in all lighting conditions. The keyboard has an embedded numeric keypad and inverted-T arrow keys. Some of the function keys are used to control the display brightness and speaker volume. See "[Keyboard](#)" (page 41).
- **Ambient light sensor:** The computer has an ambient light sensor which monitors light levels and activates the illuminated backlit keyboard and adjusts the display brightness.
- **Scrolling trackpad:** The integrated trackpad includes tap/double-tap, drag, and scroll features. For more information, see "[Trackpad](#)" (page 41).
- **Weight:** The computer weighs 6.9 pounds (3.1 kg) or less, depending on the configuration.
- **Size:** The computer is 15.4 inches (39.2 cm) wide, 10.2 inches (25.9 cm) deep, and 1.0 inches (2.6 cm) thick.

Appearance

Figure 1-1 (page 14) is a front view of the 17-inch PowerBook G4. Figure 1-2 (page 15) provides side views showing the I/O ports.

Figure 1-1 Front view of the computer

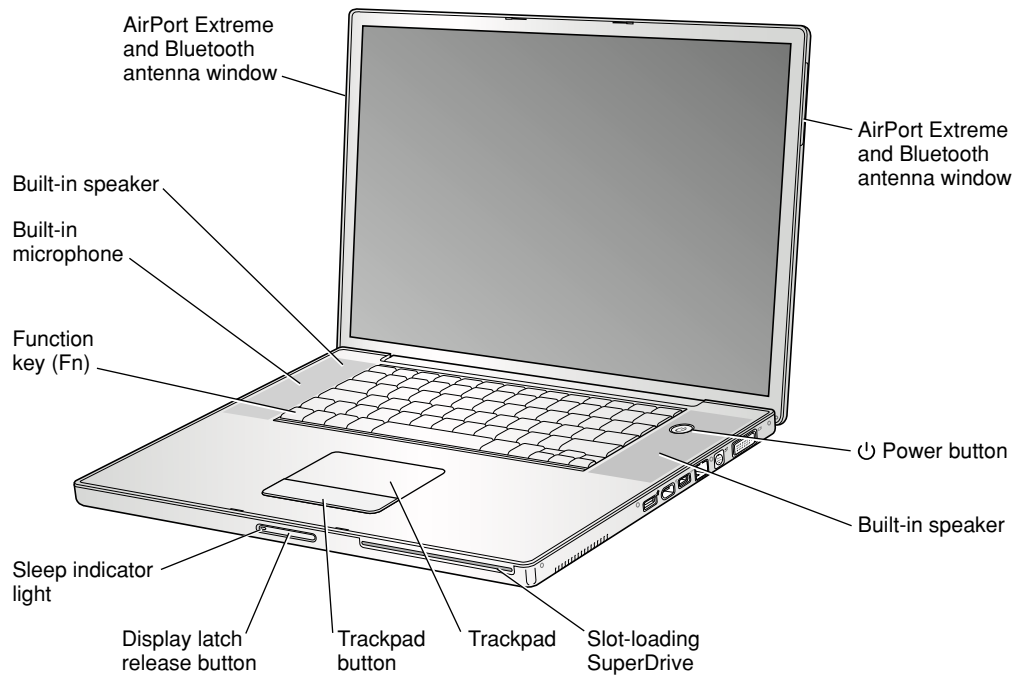
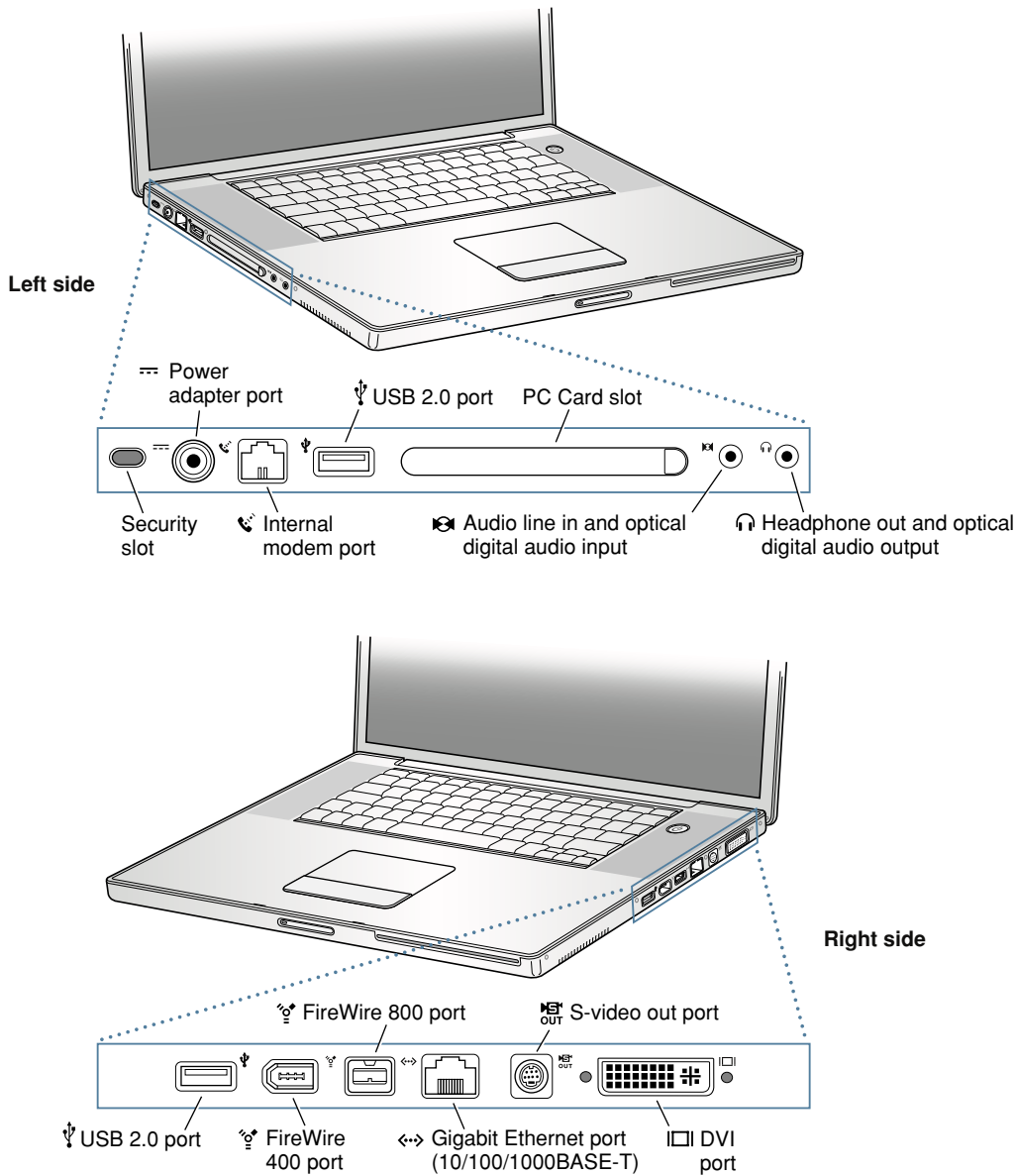

Figure 1-2 Side views showing I/O ports



Peripheral Devices

Included with the computer are a 65 W Apple Portable Power Adapter, an S-video-to-composite cable, a DVI-to-VGA cable, and a modem cable. In addition to these devices, the following peripheral devices are available separately:

- The PowerBook G4 Rechargeable Battery is available as an additional or replacement battery.
- The 65 W Apple Portable Power Adapter, which comes with the computer, is also available separately. The adapter can fully recharge a completely depleted battery in three hours or less while the computer is shut down or in sleep mode.

- The Apple DVI to ADC Adapter, which enables the 17-inch PowerBook G4 to support Apple's ADC displays.
- The Apple Keyboard, a full-featured, wired USB keyboard, is available separately.
- The Apple Mighty Mouse, a programmable, optical, wired USB mouse, is available separately.
- The Apple Wireless Mouse with built-in Bluetooth is available separately.
- The Apple Wireless Keyboard with built-in Bluetooth is available separately.
- The AirPort Extreme Base Station.

System Software

The 17-inch PowerBook G4 comes with Mac OS X version 10.4.2. For the latest information, see the references listed in "[Mac OS X](#)" (page 62).

Here are a few items of interest about the system software on the 17-inch PowerBook G4.

Open Firmware

System software on all current Macintosh models uses a design based on Open Firmware. With this approach, the ROM on the main logic board contains only the Open Firmware code needed to initialize the hardware and load an operating system. The rest of the system code is loaded into RAM from disk or from the network. For more information, see the references listed in "[Open Firmware](#)" (page 62).

Computer Identification

Rather than reading the box flag or the model string and then making assumptions about the computer's features, applications that need to find out the features of the computer should use IORegistry calls to test for the features they require. IORegistry calls are part of the IOKit API. For more information, see the references listed at "[IOKit](#)" (page 62).

Asset management software that reports the kind of computer it is running on can obtain the value of the model property from the IOService plane of the IORegistry. For the 17-inch PowerBook G4, the value of the model property is `PowerBook5,9`.

Power Management

Apple's power management techniques for the 17-inch PowerBook G4 are described in the following paragraphs.

Power Saving States

The power management protocols on the 17-inch PowerBook G4 support two power-saving states: idle and sleep.

- **Idle:** The system is idling with the main processor in a low-power state. All clocks are running; the system can return to running code within a few nanoseconds. Cache coherency is maintained in this state. The CPU automatically transitions between run and idle independent of the operating frequency. The operating frequency is based on the processor power management setting. For additional information, see "[Processor Power Management](#)" (page 17).
- **Sleep:** Most internal components are powered off and the state is saved; the DRAM state preserved for quick recovery. The processor is powered off with its state preserved in DRAM. All clocks in the system are suspended except for the 32.768 kHz timebase crystal on the PMU05 IC.

The computer automatically enters idle state after a few hundred milliseconds of inactivity. If the computer is attached to a network, it is able to respond to service requests and other events directed to the computer while it is in idle state.

While it is connected to an AC power supply, the computer can also respond to network activity when it is in sleep state. The user can enable this feature by selecting Wake-on-LAN in the Energy Saver preference pane.

When operating on the battery in sleep state, the computer consumes less than 1 watt of power, meeting the Energy Star power-saving standard. When operating on the power adapter in sleep state, the combined computer and adapter consume up to 3 to 4 watts of power.

Important: Peripherals such as PCMCIA cards and USB devices that do not conform to the computer's power management protocols prevent the computer from switching to sleep state and so deny the user the benefits of this energy-saving state.

Processor Power Management

To lower power consumption and heat generation, the 17-inch PowerBook G4 incorporates an automatic power management stepping technique. Stepping is designed to run at full, half, or quarter processor speed and voltage to meet the demands on the processor. The processor speed will switch between 1670 MHz and 833 MHz at 1.30 V for divide by 2 and between 1670 MHz and 417 MHz at .93 V for divide by 4. The memory bus speed is not shifted.

If the 17-inch PowerBook G4 detects a system temperature that is high, due to high ambient temperatures or other factors, it will immediately force the system to quarter speed mode.

The 17-inch PowerBook G4 meets all applicable safety standards, including UL 60950 and IEC 60950.

Graphics Power Management

For additional power savings and reduced heat generation, the 17-inch PowerBook G4 incorporates a dynamic graphics power management technique. When required, the graphics processor runs at a reduced voltage and slower clock rate, similar to stepping on the central processor.

CHAPTER 1

Overview of 17-inch PowerBook G4

Architecture

This chapter describes the architecture of the 17-inch PowerBook G4. It includes information about the major components on the main logic board: the microprocessor, the other main ICs, and the buses that connect them to each other and to the I/O interfaces.

Block Diagram and Buses

This section is an overview of the major ICs and buses on the computer's main logic board.

Block Diagram

[Figure 2-1](#) (page 20) is a simplified block diagram of the main logic board. The diagram shows the input and output connectors, the main ICs, and the buses that connect them together.

Figure 2-1 Block diagram

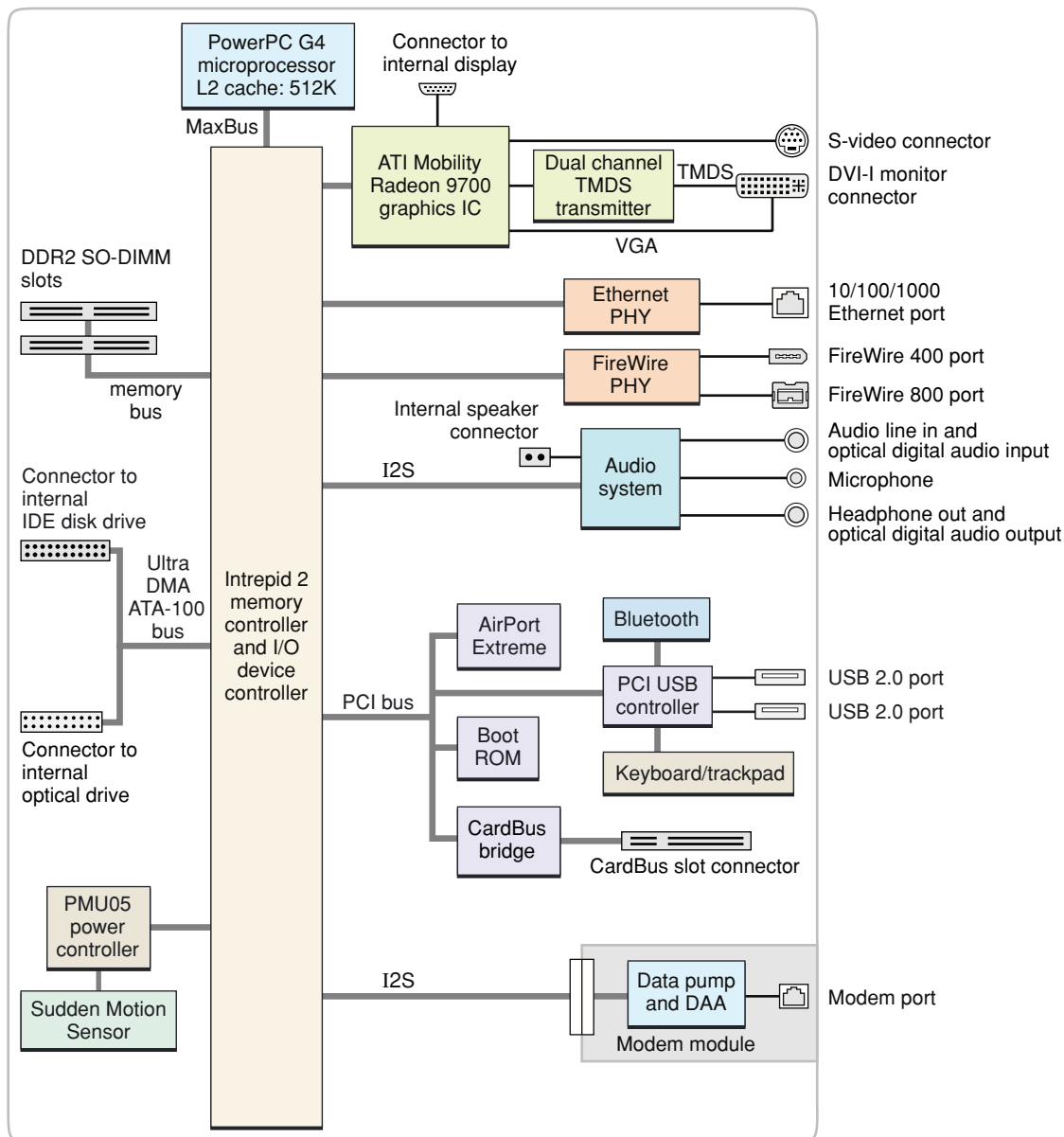

Main IC and Buses

The architecture of the 17-inch PowerBook G4 is designed around the PowerPC G4 microprocessor and the Intrepid 2 IC, which contains the memory controller and I/O device controller.

The PowerPC G4 microprocessor is connected to the Intrepid 2 IC by a MaxBus bus. The bus clock speed is 167 MHz. Other buses that connect with the Intrepid 2 IC are summarized in [Table 2-1](#) (page 22), which is in the section "[Intrepid 2 Controller Functions and Buses](#)" (page 21).

The Intrepid 2 I/O controller has a 32-bit PCI bus with a bus clock speed of 33 MHz. That bus also connects to the Boot ROM, the CardBus controller, the USB 2.0 controller, and the wireless LAN module. The Intrepid 2 IC has other buses that connect with the hard disk drive and the optical drive, the power controller IC, the audio IC, and the internal modem module.

Each of the components listed here is described in one of the following sections.

Microprocessor and Caches

The microprocessor communicates with the rest of the system by way of a 64-bit MaxBus bus to the Intrepid 2 IC. The microprocessor has a separate bus to its internal second-level cache.

PowerPC G4 Microprocessor

The PowerPC G4 microprocessor used in the 17-inch PowerBook G4 has many powerful features, including an efficient pipelined system bus called MaxBus.

Features of the PowerPC G4 include

- 32-bit PowerPC implementation
- superscalar PowerPC core
- Velocity Engine (AltiVec technology): 128-bit-wide vector execution unit
- dual 32 KB instruction and data caches
- an on-chip level 2 (L2) cache consisting of 512 KB with a clock speed ratio of 1:1
- high bandwidth MaxBus (also compatible with 60x bus)
- fully symmetric multiprocessing capability

The PowerPC G4 microprocessor in the 17-inch PowerBook G4 runs at a clock speed of 1.67 GHz.

Level 2 Cache

The data storage for the L2 cache consists of 512 KB of fast static RAM that is built into the microprocessor chip along with the cache controller and tag storage. The built-in L2 cache runs at the same clock speed as the microprocessor.

Intrepid 2 Controller Functions and Buses

The Intrepid 2 IC provides the functions of a memory controller and an I/O device controller in the 17-inch PowerBook G4.

Note: In the device tree, the I/O controller is named "mac-io".

In addition to the buses listed in [Table 2-1](#) (page 22), the Intrepid 2 IC also has separate interfaces to the physical layer (PHY) ICs for Ethernet and FireWire, and an I2C (inter-IC control bus) interface that is used for configuring the memory subsystem.

Table 2-1 Buses supported by the Intrepid 2 IC with DDR2 RAM

Bus	Destinations	Width of data path	Bus clock speed
MaxBus	Microprocessor	64 bits	167 MHz
Memory	System RAM	64 bits	333 MHz
PCI	AirPort Extreme, PC Card/CardBus, Boot ROM, USB 2.0 controller	32 bits	33 MHz
AGP4X	Graphics IC	32 bits	133 MHz
Ultra DMA ATA-100	Hard drive	16 bits	100 MBps
Ultra DMA ATA-100	SuperDrive	16 bits	16.7 MBps

The following sections describe the subsystems that are connected to the Intrepid 2 IC.

System RAM

The memory subsystem in the 17-inch PowerBook G4 supports two slots for 200-pin, PC2-4200 DDR2 SDRAM SO-DIMMs (small-outline dual inline memory modules) running at 333 MHz. The data bus to the RAM and DIMM is 64 bits wide, and the memory interface is synchronized to the MaxBus bus interface at 167 MHz. See "[RAM Expansion Slots](#)" (page 57).

Boot ROM

The boot ROM is connected to the Intrepid 2 IC by way of the high byte of the PCI bus plus three additional control signals: chip select, write enable, and output enable. The boot ROM is a 1 M by 8 bit device.

FireWire Controllers

The Intrepid 2 IC FireWire controller supports IEEE 1394a for a maximum data rate of 400 Mbps (50 MBps) and IEEE 1394b for a maximum data rate of 800 Mbps (100 MBps). The Intrepid 2 IC provides DMA (direct memory access) support for the FireWire interface.

The controller in the Intrepid 2 IC implements the FireWire link layer. A physical layer IC, called a PHY, implements the electrical signaling protocol of the FireWire interface and provides the electrical signals to the port. For more information, see "[FireWire 400 Connector](#)" (page 28) and "[FireWire 800 Connector](#)" (page 29).

Ethernet Controller

The Intrepid 2 IC includes an Ethernet media access controller (MAC) that implements the link layer. The Intrepid 2 IC provides DB-DMA support for the Ethernet interface.

The Ethernet controller in the Intrepid 2 IC is connected to a PHY interface IC that provides the electrical signals to the port. The PHY is capable of operating in either 10BASE-T, 100BASE-T, or 1000BASE-T mode: The actual speed of the link is automatically negotiated by the PHY and the hub or switch to which it is connected. For more information, see "[Ethernet Port](#)" (page 32).

The PHY supports Auto-MDIX, which allows the use of straight-through cables in crossover situations (and conversely). For more information, see "[Ethernet Port](#)" (page 32).

Video Display Subsystem

The video display subsystem contains the graphics controller IC along with 128 MB DDR SDRAM memory and dual link DVI functionality. The ATI Mobility Radeon 9700 graphics IC contains 2D and 3D acceleration engines, front-end and back-end scalars, a CRT controller, and an AGP4x bus interface with bus master capability.

The features of the ATI Mobility Radeon 9700 include

- support for 128 MB of DDR video memory with 128-bit interface
- 2D and 3D graphics acceleration
- transform acceleration
- lighting acceleration
- video acceleration
- support for MPEG decoding
- support for video mirror mode
- support for dual-display mode
- S-video output for a TV monitor

The interface between the graphics IC and the rest of the system is an AGP4x (accelerated graphics port, quadruple speed) bus on the Intrepid 2 IC. The AGP bus has 32 data lines, a clock speed of 133 MHz, and supports deeply pipelined read and write operations.

The graphics IC uses a graphics address remapping table (GART) to translate AGP logical addresses into physical addresses. The graphics driver software can allocate memory in both the graphics SDRAM and the main memory.

The graphics IC supports the internal flat-panel display and an external monitor. The external monitor can either mirror the built-in display or show additional desktop space (dual-display mode). For information about the displays and supported resolutions, see "[Flat-Panel Display](#)" (page 47) and "[External Monitors](#)" (page 48).

DMA Support

The Intrepid 2 IC provides DB-DMA (descriptor-based direct memory access) support for the following I/O channels:

- Ultra DMA ATA interface to the the internal hard drive
- I2S interface to the built-in modem
- I2S channel to the audio IC

The DB-DMA system provides a scatter-gather process based on memory resident data structures that describe the data transfers. The DMA engine is enhanced to allow bursting of data files for improved performance.

Interrupt Support

The Intrepid 2 IC has an interrupt controller (MPIC) that handles interrupts generated within the IC as well as external interrupts, such as those from the Ethernet and FireWire controllers.

USB Interface

The internal USB 1.1 devices are connected via the PCI USB controller; see "[PCI USB 2.0 Controller](#)" (page 26).

Ultra DMA ATA-100 Interface

The Intrepid 2 IC provides an Ultra DMA ATA-100 channel that is connected to the internal hard disk drive. The Intrepid 2 IC provides DB-DMA (descriptor-based direct memory access) support for the ATA-100 interface.

The internal hard disk drive is connected as cable-select in an ATA Device 0/1 configuration. For more information, see "[Hard Disk Drive](#)" (page 35).

The SuperDrive is an ATAPI drive and is cable-selected in an ATA device configuration. For more information, see "[SuperDrive](#)" (page 39).

Modem Support

The internal modem is connected to an internal I2S port. The Intrepid 2 IC provides DB-DMA support for the modem interface. The modem provides digital call progress signals to the audio circuitry.

The internal modem is a separate module that contains the data pump IC and the interface to the telephone line (DAA). For more information about the modem, see "[Internal Modem](#)" (page 33).

Audio Circuitry

The audio circuitry is connected to the Intrepid 2 IC by a standard I2S (inter-IC sound) bus. The Intrepid 2 IC provides DB-DMA (descriptor-based direct memory access) support for the I2S port.

Note: In the device tree, the sound circuitry is named “sound”.

The audio circuitry includes a signal processing IC that handles the equalization and volume control functions, a codec IC that performs A-to-D and D-to-A conversion, and a power amplifier that drives the headphone jack.

All audio is handled digitally inside the computer. The audio circuitry performs digital-to-analog conversion for the audio signals to the internal speakers and the headphone jack.

For a description of the features of the audio system, see ["Audio System"](#) (page 53).

Power Controller

The power management controller is a custom IC (PMU05), which controls the Sudden Motion Sensor (SMS), ambient light sensor (ALS), keyboard backlit LED, and the sleep LED. When the 17-inch PowerBook G4 is on and the LCD is off, the sleep LED emits a steady light (no pulsing) to indicate power to the system.

The PMU05 also supports several power-saving modes of operation, including idle, doze, and sleep. For more information, see ["Power Management"](#) (page 16).

Note: In the device tree, the power controller is named “via-pmu”.

A device's ID voltage limits determines how the PMU identifies the power adapter. The 17-inch PowerBook G4 is designed to use the 65-Watt Apple Portable Power Adapter which ships with it. Although you can use a 45-Watt Apple portable power adapter with a 17-inch PowerBook G4, it may not provide sufficient power during some activities and power may be drawn temporarily from the battery. Should the battery become discharged, you may need to plug in the 65-Watt Apple Portable Power Adapter that came with the computer in order to start it up.

The 17-inch PowerBook G4 has a variable speed fan control circuit and a thermal circuit that will force the unit into reduce-processor mode at 68 degrees Celsius and into sleep mode if the processor temperature exceeds 79 degrees Celsius.

The 17-inch PowerBook G4 can operate from a 15 volt power outlet on an airline, but for safety reasons, the computer will not allow battery charging. In order for the computer to detect the connection to airline power, the airline power cable should have a sense resistor of 24.3 K ohms +/-1% connected between the power plug's shell and ground.

The process to reset the PMU is listed below.

1. If the computer is on, turn it off.
2. Disconnect the AC Adapter and remove the battery.
3. Press and hold down the power button for 5 seconds, and then release.
4. Wait 5 seconds.
5. Connect the battery and AC Adapter.
6. Press the power button to restart the computer.

Sudden Motion Sensor

The Sudden Motion Sensor (SMS) helps to detect an accidental drop or fall by sensing a change in position and accelerated movement of the 17-inch PowerBook G4. In the event of a drop, the SMS parks the hard drive heads to help lessen the risk of damage to the hard drive on impact. When the SMS senses that the PowerBook position is once again stable, it unlocks the hard drive heads and the system is up and running within seconds.

AirPort Extreme and Bluetooth Module

The 17-inch PowerBook G4 has a combined, internal AirPort Extreme and Bluetooth module. The antennas are built into the system, one on either side of the display.

The 54 Mbps AirPort Extreme wireless LAN is connected via the PCI bus. For information about operation, see "[AirPort Extreme](#)" (page 33).

Bluetooth is connected via a USB 1.1 bus. For more information on Bluetooth technology, refer to "[Bluetooth 2.0 with EDR](#)" (page 35).

PC Card/CardBus Controller IC

The interface to the PC Card slot is connected to the PCI bus. The CardBus controller IC is a PCI1510A device made by Texas Instruments. It supports both 16-bit PC Cards and 32-bit CardBus Cards.

PCI USB 2.0 Controller

The 17-inch PowerBook G4 CPU uses a PCI USB controller with one Enhanced Host Controller Interface (EHCI) function and two Open Host Controller Interface (OHCI) functions. The controller supports two external USB 2.0 ports, the trackpad, keyboard, and Bluetooth.

The two external USB ports comply with the Universal Serial Bus Specification 2.0. The USB register set complies with the EHCI and OHCI specifications. For more information, see "[USB 2.0 Ports](#)" (page 27).

The two external USB 2.0 connectors support USB devices with data transfer rates of up to 480 Mbps. For more information about the connectors, see "[USB Connectors](#)" (page 27).

USB 2.0 devices connected to the 17-inch PowerBook G4 are required to support USB-suspend mode as defined in the USB specification. For additional reference information, see "[USB Interface](#)" (page 63).

The USB ports on the 17-inch PowerBook G4 comply with the Universal Serial Bus Specification 2.0. The USB controllers comply with the EHCI specification; the companion controllers comply with the OHCI specification. The internal USB 1.1 interface complies with the OHCI specification, see "[USB Interface](#)" (page 24).

Devices and Ports

This chapter describes both the built-in I/O devices and the ports for connecting external I/O devices. Each of the following sections describes an I/O port or device.

USB 2.0 Ports

The 17-inch PowerBook G4 has two external USB 2.0 ports that can be used to connect additional I/O devices such as a USB mouse, printers, scanners, and storage devices.

The USB ports on the 17-inch PowerBook G4 comply with the Universal Serial Bus Specification 2.0. For more information about USB on Macintosh computers, consult the references at "USB Interface" (page 63).

Note: Some self-powered USB devices inadvertently violate electrical specifications for self-powered USB devices. For details and ways to avoid this design issue, refer to <http://developer.apple.com/qa/hw/hw82.html>.

USB Connectors

The USB ports use USB Type A connectors, which have four pins each. Two of the pins are used for power and two for data. [Figure 3-1](#) (page 27) is an illustration of a Type A port and matching connector. [Table 3-1](#) shows the pin assignments.

Figure 3-1 USB Type A port

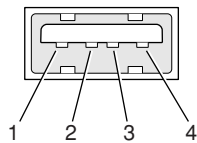

Table 3-1 Pin assignments on the USB port

Pin	Signal name	Description
1	VCC	+5 VDC
2	D-	Data -
3	D+	Data +
4	GND	Ground

The computer provides 5-volt power at 500 mA for each of the two ports.

The external USB 2.0 ports support low-speed (1.5 Mbps), full-speed (12 Mbps), and high-speed (480 Mbps) data transfers. High-speed operation requires the use of shielded cables.

The 17-inch PowerBook G4 supports all four data transfer types defined in the USB specification.

USB devices can provide a remote wakeup function for the computer. The USB root hub in the computer is set to support remote wakeup whenever a device is attached to the bus.

USB Class Drivers

Class drivers are software components that are able to communicate with many USB devices of a particular kind. If the appropriate class driver is present, any number of compliant devices can be plugged in and start working immediately without the need to install additional software.

FireWire Ports

The 17-inch PowerBook G4 has one FireWire 400 (IEEE 1394a) port and one FireWire 800 (IEEE 1394b) port. Both FireWire ports

- support booting the system from a mass storage device
- support target disk mode

The two FireWire ports share a single power supply that can provide up to 14 watts total. Both ports are on the same FireWire bus and can connect to up to 62 other FireWire devices.

The FireWire hardware and software provided with the 17-inch PowerBook G4 are capable of all asynchronous and isochronous transfers defined by IEEE standard 1394a and 1394b.

For additional information about the FireWire interface and the Apple API for FireWire device control, refer to the resources listed at "[FireWire Interface](#)" (page 64).

FireWire 400 Connector

The 6-pin FireWire 400 technology

- supports serial I/O at 100, 200, and 400 Mbps
- provides up to 7 watts of power when the computer system is on or when the power adapter is connected and in sleep mode

The FireWire 400 connector has six contacts, as shown in [Figure 3-2](#) (page 29). The connector pin assignments are shown in [Table 3-2](#) (page 29).

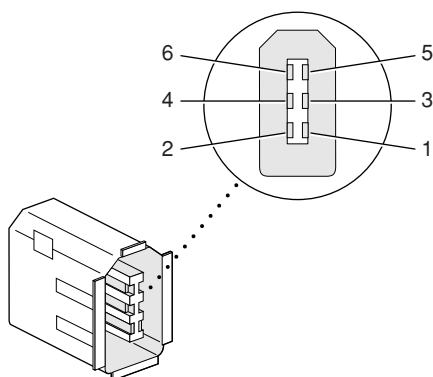
Figure 3-2 6-pin FireWire connector**Table 3-2** Pin assignments on the 6-pin FireWire connector

Pin	Signal name	Description
1	Power	Unregulated DC; 12.8 V
2	Ground	Ground return for power and inner cable shield
3	TPB-	Twisted-pair B, differential signals
4	TPB+	Twisted-pair B, differential signals
5	TPA-	Twisted-pair A, differential signals
6	TPA+	Twisted-pair A, differential signals
Shell	—	Outer cable shield

When the computer is on or the power adapter is connected, the power pin provides a maximum voltage of 12.8 V (no load) and 7 W power per port. Maximum output current for both ports combined is 1.5 A and is controlled by a self-resetting fuse.

Pin 2 of the 6-pin FireWire connector is ground for both power and the inner cable shield. If a 4-pin connector is used on the other end of the FireWire cable, its shell should be connected to the wire from pin 2.

The signal pairs are crossed in the cable itself so that pins 5 and 6 at one end of the cable connect with pins 3 and 4 at the other end. When transmitting, pins 3 and 4 carry data and pins 5 and 6 carry clock; when receiving, the reverse is true.

FireWire 800 Connector

The FireWire 800 port on the 17-inch PowerBook G4 is based on IEEE 1394b and enables a 800 Mbps transfer rate. FireWire 800 uses a 9-pin connector and is backwards compatible with original 1394 FireWire devices with 6-pin or 4-pin connectors. With the appropriate cable, the 9-pin port works seamlessly with legacy FireWire devices. Cables are available to go from both 6-pin and 4-pin connectors to a 9-pin, and 9-pin to 9-pin.

Note: FireWire adapter cables are not included with the computer.

The 9-pin FireWire 800 connector is shown in [Figure 3-3](#) (page 30). Its connector signals and pin assignments are shown in [Table 3-3](#) (page 30).

Figure 3-3 9-pin FireWire 800 connector

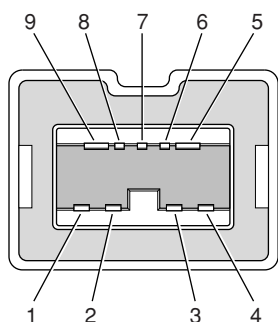

Table 3-3 Signals on the 9-pin FireWire 800 connector

Pin	Signal name	Description
1	TPB-	Twisted-pair B Minus
2	TPB+	Twisted-pair B Plus
3	TPA-	Twisted-pair A Minus
4	TPA+	Twisted-pair A Plus
5	TPA (R)	Twisted-pair A Ground Reference
6	VG	Power Ground
7	SC	Status Contact (no connection; reserved)
8	VP	Power Voltage (approximately 12.8 V DC)
9	TPB (R)	Twisted-pair B Ground Reference

VP (pin 8) provides up to 7 W power, shared with the other FireWire connectors. The voltage on the power pin is approximately 12.8 V.

The 9-pin FireWire 800 port is capable of operating at 100, 200, 400, and 800 Mbps, depending on the device to which it is connected. The FireWire 800 port is bilingual in that it supports both IEEE 1394a and 1394b. Using a cable with a 9-pin connector at one end and a 4-pin or 6-pin connector at the other, the 9-pin port is capable of directly connecting to all existing FireWire devices. Using a cable with 9-pin connectors at both ends, the 9-pin port is capable of operating at 800 Mbps.

The IEEE 1394b standard defines long-haul media using Cat 5 UTP and several kinds of optical fiber. The 17-inch PowerBook G4 is interoperable with such cables but cannot be directly connected to them. To use long-haul cables, connect the computer to a 1394b hub that has the desired kind of long-haul connectors. If the hub has a bilingual port, that port can be connected to any of the computer's FireWire ports. If the hub has a beta-only port, it can be connected only to the computer's 9-pin port.

FireWire Device Programming

Mac OS X includes general support for the FireWire bus and specific support for various kinds of FireWire devices and protocols. Developers can use the built-in support or provide additional applications and drivers for use with their products.

The general FireWire services will configure the FireWire bus, scan the bus for new devices, and allow multiple drivers and devices to share a single FireWire interface cooperatively. The general services also publish information about the bus and the devices in the IO Registry, so that IOKit can match protocols and drivers to each connected FireWire device.

The specific device and protocol support in Mac OS X as provided with the 17-inch PowerBook G4 includes the following:

- General services for Serial Bus Protocol 2 (SBP-2) and support for most mass storage devices using SBP-2, such as hard disk drives, optical drives, flash card readers, Target Disk Mode (see "[Target Disk Mode](#)" (page 31)), and the iPod. Mac OS X can boot from most of these devices.
- General services for the Audio Video Control (AV/C) protocol and support for most digital video (DV) cameras and decks using this protocol, including video capture through standard QuickTime APIs.
- A QuickTime device driver for IIDC/DCAM type cameras such as the iSight.
- A network device driver supporting IP (Internet Protocol) over FireWire according to IEEE RFC 2734.
- Additional services for user-space and kernel access to all FireWire resources.

For information on writing FireWire drivers or applications, download the latest FireWire SDK from <http://developer.apple.com/sdk/>.

For additional references, refer to "[FireWire Interface](#)" (page 64).

Target Disk Mode

One option at boot time is to put the computer into a mode of operation called target disk mode.

When the 17-inch PowerBook G4 is in target disk mode and connected to another Macintosh computer by a FireWire cable, the 17-inch PowerBook G4 operates like a FireWire mass storage device with the SBP-2 (Serial Bus Protocol) standard. Target disk mode has two primary uses:

- high-speed data transfer between computers
- diagnosis and repair of a corrupted internal hard drive

The 17-inch PowerBook G4 can operate in target disk mode as long as the other computer has a FireWire 1394a or 1394b port and is running either Mac OS X (any version) or Mac OS 9 with FireWire software version 2.3.3 or later.

To put the computer into target disk mode, hold down the T key while the computer is starting up. When Open Firmware detects the T key during the boot process, it transfers control to special Open Firmware code.

To take the computer out of target disk mode, press the power button.

Note: The 17-inch PowerBook G4 is designed to use the 65 W Apple Portable Power Adapter which ships with it. A 45 W Apple portable power adapter works with the 17-inch PowerBook G4, but may provide insufficient power during some activities and power may be drawn temporarily from the battery. Therefore a 45 W power adapter is not recommended.

Ethernet Port

The 17-inch PowerBook G4 has a built-in Ethernet port that supports 10BASE-T, 100BASE-T, and 1000BASE-T transfer rates. In operation, the actual speed of the link is auto-negotiated between the computer's PHY device and the network hub or switch to which it is connected.

The connector for the Ethernet port is an RJ-45 connector on the right side of the computer. [Table 3-4](#) (page 32) shows the signals and pin assignments for 10BASE-T and 100BASE-T operation. [Table 3-5](#) (page 32) shows the signals and pin assignments for 1000BASE-T operation.

Table 3-4 Signals for 10BASE-T and 100BASE-T operation

Pin	Signal name	Signal definition
1	TXP	Transmit (positive lead)
2	TXN	Transmit (negative lead)
3	RXP	Receive (positive lead)
4	–	Not used
5	–	Not used
6	RXN	Receive (negative lead)
7	–	Not used
8	–	Not used

Table 3-5 Signals for 1000BASE-T operation

Pin	Signal name	Signal definition
1	TRD+(0)	Transmit and receive data 0 (positive lead)
2	TRD–(0)	Transmit and receive data 0 (negative lead)
3	TRD+(1)	Transmit and receive data 1 (positive lead)
4	TRD+(2)	Transmit and receive data 2 (positive lead)

Pin	Signal name	Signal definition
5	TRD-(2)	Transmit and receive data 2 (negative lead)
6	TRD-(1)	Transmit and receive data 1 (negative lead)
7	TRD+(3)	Transmit and receive data 3 (positive lead)
8	TRD-(3)	Transmit and receive data 3 (negative lead)

To interconnect two computers for 1000BASE-T operation, you must use 4-pair cable (Category 5 or 6).

The Ethernet port on the 17-inch PowerBook G4 supports Auto-MDIX. It switches between MDI (Medium Dependent Interface) and MDI-X operation automatically, so it can be connected to another device by either a straight-through cable or a cross-over cable.

The Ethernet interface in the 17-inch PowerBook G4 conforms to the ISO/IEC 802.3 specification, where applicable, and complies with IEEE specifications 802.3i (10BASE-T), 802.3u-1995 (100BASE-T), and 802.3ab (1000BASE-T).

Internal Modem

The 17-inch PowerBook G4 comes with a built-in I2S modem. The connector for the modem is an RJ-11 connector on the left side of the computer.

The modem has the following features:

- modem bit rates up to 56 Kbps (supports V.34, V.90, and V.92 modem standards)
- fax modem bit rates up to 14.4 Kbps

The modem driver controls the modem hardware and presents a virtual serial port to the operating system and applications.

Note: 56 Kbps technology refers to download speeds only and requires compatible modems at server sites. Other conditions may limit modem speed. FCC limitations allow a maximum of 53 Kbps during download transmissions.

AirPort Extreme

The 17-inch PowerBook G4 is equipped with AirPort Extreme, a fully-integrated, internal wireless LAN module that is fully compliant with the IEEE 802.11g standard. By communicating wirelessly with a base station, AirPort Extreme can be used for internet access, email access, and file exchange. A base station provides the connection to the Internet or the bridge between the wireless signals and a wired LAN or both. The AirPort Extreme Base Station has connectors for a wired LAN, a DSL or cable modem, or a standard telephone line using the optional 56K modem that is built-in on some models.

AirPort Extreme transmits and receives data at speeds up to 54 Mbps, comparable to wired networking speeds. AirPort Extreme is also compatible with other devices that follow the IEEE 802.11b standard, including PC's. For more information about compatibility, see the reference at "[Wireless Networks](#)" (page 64).

Note: As is the case with the existing IEEE 802.11b standard, actual data throughput speeds will be lower than the indicated maximum connection speeds. Inherent in wireless LAN systems, bandwidth overhead is required for wireless routing, scrambling, security error correction, and other processes.

Data Security

AirPort Extreme has several features designed to maintain the security of the user's data.

- In 802.11b mode, the system uses direct-sequence spread-spectrum (DSSS) technology that uses a multi-bit spreading code that effectively scrambles the data for any receiver that lacks the corresponding code.
- The system can use an Access Control List of authentic network client ID values (wireless and MAC addresses) to verify each client's identity before granting access to the network.
- When communicating with a base station, AirPort Extreme uses 64-bit and 128-bit WEP encryption and WPA personal and enterprise modes to encode data while it is in transit. Additional security features may be available via firmware upgrades as 802.11 enhancements are ratified by IEEE.
- The AirPort Extreme Base Station can be configured to use NAT (Network Address Translation), protecting data from Internet hackers.
- The AirPort Extreme Base Station can authenticate users by their unique Ethernet IDs, preventing unauthorized computers from logging into your network. Network administrators can take advantage of RADIUS compatibility, used for authenticating users over a remote server. Smaller networks can offer the same security using a local look-up table located within the base station.

As an additional data security measure, VPN can be used in conjunction with the AirPort Extreme data security.

AirPort Extreme Hardware

AirPort Extreme uses both OFDM (orthogonal frequency-division multiplexing) and DSSS technologies. Using DSSS, AirPort Extreme is interoperable with PC-compatible wireless LANs that conform to the 802.11b standard at speeds of 11 Mbps, 5.5 Mbps, 2 Mbps, and 1 Mbps. Using OFDM, AirPort Extreme is compatible with all 802.11g standard speeds.

Two antennas are built into the computer, on either side of the flat-panel display.

AirPort Extreme Software

The 17-inch PowerBook G4 includes software for setting up and using AirPort Extreme:

- AirPort Extreme Setup Assistant, an easy-to-use program that guides users through the steps necessary to set up AirPort Extreme or set up an AirPort Extreme Base Station.

- Users can switch between wireless networks and can create and join peer-to-peer networks. These functions are accessed via the AirPort Extreme status menu.
- AirPort Extreme Admin Utility, a utility for advanced users and system administrators. With it the user can edit the administrative and advanced settings needed for some advanced configurations.

Bluetooth 2.0 with EDR

Bluetooth 2.0 with enhanced data rate (EDR) is an open specification that enables short-range wireless connections between desktop and laptop computers and a host of other peripheral devices. Bluetooth support is built into Mac OS X and compliant with Bluetooth specification 2.0. It operates on a globally available 2.4 GHz frequency band (ISM band) for worldwide compatibility and has a maximum throughput of 3 Mbps.

The Bluetooth technology supports the following profiles:

- serial port (SPP) — provides a wireless serial connection to other Bluetooth devices
- dial-up networking (DUN) — enables a mobile phone to act as a modem
- object push (OPP) — enables the transfer of files between Bluetooth devices
- human interface device (HID) — enables the use of Bluetooth input devices (keyboards and mice)
- Bluetooth file transfer profile (FTP) — enables browsing of the file system of other Bluetooth devices which support Bluetooth FTP
- hardcopy cable replacement profiler (HCRP) — describes how to send rendered data over a Bluetooth link to a device, such as a printer. Although other profiles can be used for printing, the HCRP is specially designed to support hardcopy applications.
- headset profile (HSP) — enables the use of Bluetooth-enabled wireless headsets for applications such as iChat. This profile does not enable use of Apple Speech Recognition due to the fact that it is a low-precision audio channel.

For more information on Bluetooth technology, refer to "[Bluetooth](#)" (page 64).

Hard Disk Drive

The 17-inch PowerBook G4 has a 5400 rpm internal hard disk drive with a storage capacity of 120 GB. A 100 GB 7200 rpm disk drive is available as a build-to-order option. The drive has fluid dynamic bearings for quieter operation. The drive uses the Ultra ATA-100 (IDE, integrated drive electronics) interface and is ATA-6 compatible. Data Transfer Mode for the drive is ATA-100.

The software that supports the internal hard disk is the same as that in previous models with internal IDE drives and includes DMA support.

To obtain the reference documents listed here, see the reference links at "[ATA Devices](#)" (page 63).

Hard Disk Dimensions

Figure 3-4 (page 36) shows the maximum dimensions of the hard disk and the location of the mounting holes. The minimum clearance between any conductive components on the drive and the bottom of the mounting envelope is 0.5 mm.

Figure 3-4 Maximum dimensions of the internal hard disk

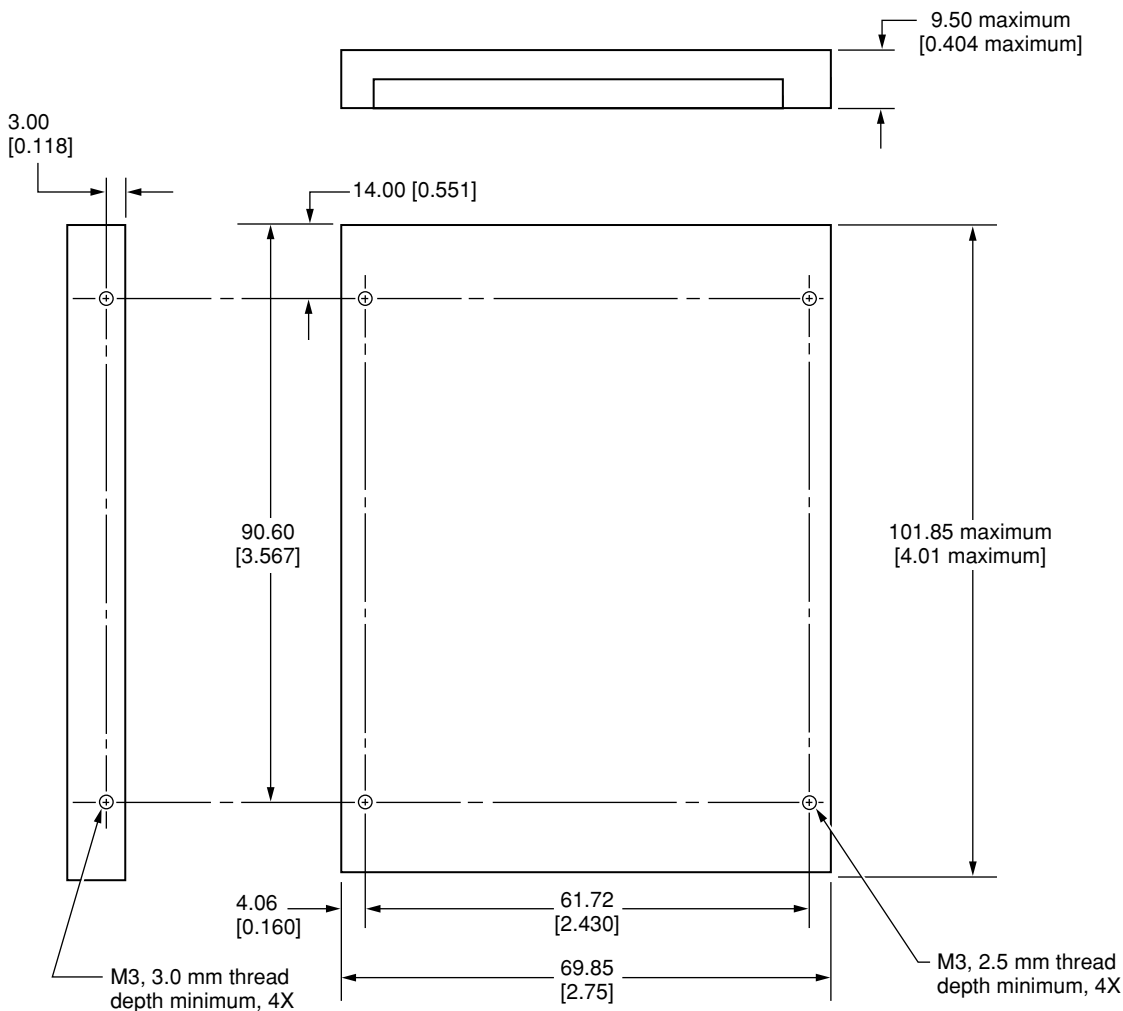

Note: Dimensions are in millimeters [inches].

Hard Disk Connector

The internal hard disk has a 48-pin connector that carries both the ATA signals and the power for the drive. The connector has the dimensions of a 50-pin connector, but with one row of pins removed, as shown in Figure 3-5 (page 37). The remaining pins are in two groups: pins 1–44, which carry the signals and power, and pins 45–48, which are reserved. Pin 20 has been removed, and pin 1 is located nearest the gap, rather than at the end of the connector.

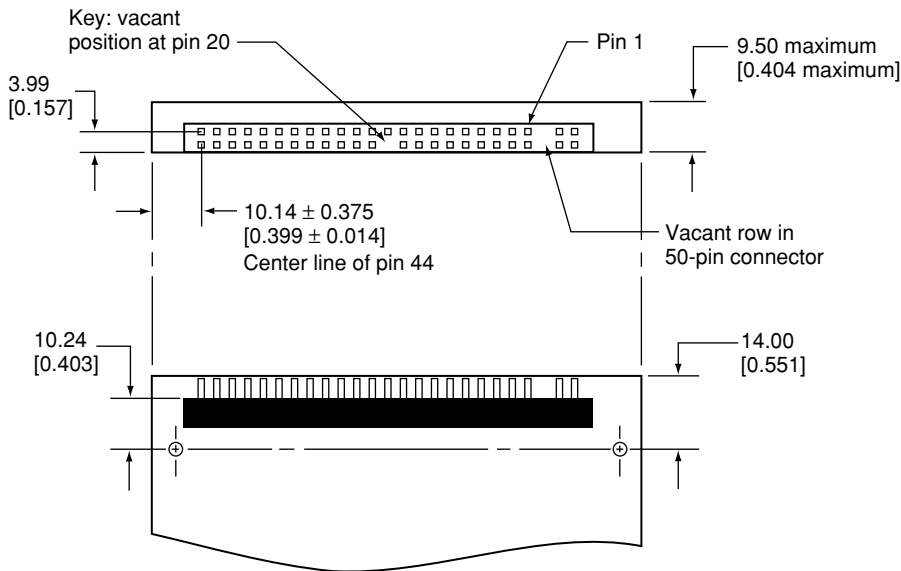
Figure 3-5 Hard disk connector and location

Note: Dimensions are in millimeters [inches].

Signal Assignments

Table 3-6 (page 37) shows the signal assignments on the 44-pin portion of the hard disk connector. A slash (/) at the beginning of a signal name indicates an active-low signal.

Table 3-6 Pin assignments on the ATA hard disk connector

Pin number	Signal name	Pin number	Signal name
1	/RESET	2	GROUND
3	DD7	4	DD8
5	DD6	6	DD9
7	DD5	8	DD10
9	DD4	10	DD11
11	DD3	12	DD12
13	DD2	14	DD13
15	DD1	16	DD14
17	DD0	18	DD15
19	GROUND	20	KEY
21	DMARQ	22	GROUND

Pin number	Signal name	Pin number	Signal name
23	/DIOW, /STOP	24	GROUND
25	/DIOR, /HDMARDY, HSTROBE	26	GROUND
27	IORDY, /DDMARDY, DSTROBE	28	CSEL
29	/DMACK	30	GROUND
31	INTRQ	32	obsolete
33	DA1	34	/PDIAG, /CBLID
35	DA0	36	DA2
37	/CS0	38	/CS1
39	/DASP	40	GROUND
41	+5V LOGIC	42	+5V MOTOR
43	GROUND	44	Reserved

/IOCS16 is not used; see [Table 3-7](#) (page 38).

ATA Signal Descriptions

[Table 3-7](#) (page 38) describes the signals on the ATA hard disk connector.

Table 3-7 Signals on the ATA hard disk connector

Signal name	Signal description
DA(0–2)	Device address; used by the computer to select one of the registers in the ATA drive. For more information, see the descriptions of the CS0 and CS1 signals.
DD(0–15)	Data bus; buffered from IOD(16–31) of the computer's I/O bus. DD(0–15) are used to transfer 16-bit data to and from the drive buffer. DD(8–15) are used to transfer data to and from the internal registers of the drive, with DD(0–7) driven high when writing.
/CBLID	The host checks this signal after power on or hardware reset to detect whether an 80-conductor cable is present.
/CS0	Register select signal. It is asserted low to select the main task file registers. The task file registers indicate the command, the sector address, and the sector count.
/CS1	Register select signal. It is asserted low to select the additional control and status registers on the ATA drive.
CSEL	Cable select; not available on this computer (n.c.).
/DASP	Device active or slave present.

Signal name	Signal description
/DDMARDY	Drive ready to receive Ultra DMA data.
/DIOR	I/O data read strobe.
/DIOW	I/O data write strobe.
/DMACK	Used by the host to initiate a DMA transfer in response to DMARQ.
DSTROBE	Strobe for Ultra DMA data transfers to host.
/HDMARDY	Ultra DMA data ready.
HSTROBE	Strobe for Ultra DMA data transfers from host.
IORDY	I/O ready; when driven low by the drive, signals the CPU to insert wait states into the I/O read or write cycles.
DMARQ	Asserted by the device when it is ready to transfer data to or from the host.
INTRQ	Interrupt request. This active high signal is used to inform the computer that a data transfer is requested or that a command has terminated.
/PDIAG	Asserted by device 1 to indicate to device 0 that it has completed the power-on diagnostics.
/RESET	Hardware reset to the drive; an active low signal.
/STOP	Stop request; an active low signal.
Key	This pin is the key for the connector.

The built-in ATA devices are connected to the I/O bus through bidirectional bus buffers.

SuperDrive

The 17-inch PowerBook G4 has a slot-loading SuperDrive. The SuperDrive can read and write DVD media and CD media as shown in Table 3-8. The SuperDrive drive also provides DVD-Video playback.

Table 3-8 Media read and written by the SuperDrive

Media type	Reading speed (maximum)	Writing speed
DVD-R	6x (CAV max)	8x (ZCLV)
DVD-RW	6x (CAV max)	4x (ZCLV)
DVD+R	6x (CAV max)	8x (ZCLV)
DVD+RW	6x (CAV max)	4x (ZCLV)
DVD+R DL	6x max CAV	2.4x max CLV

Media type	Reading speed (maximum)	Writing speed
DVD-ROM	8x (CAV max, single layer) 6x (CAV max, dual layer)	–
CD-R or CD-ROM	24x (CAV max)	24x (ZCLV)
CD-RW	24x (CAV max)	16x (XCLV) ultra high speed media

The Apple SuperDrive is an ATAPI drive and writes to DVD-R 4.7 gigabyte General Use media. These discs are playable in most standard DVD players and computer DVD-ROM drives.

Digital audio signals from the SuperDrive can be played through the audio outputs under the control of the System Preferences. The SuperDrive is an ATAPI drive and is cable-selected in an ATA device configuration.

Important: The SuperDrive supports only 12 cm disc media. It does not support 8 cm discs or noncircular media.

Combo Drive

A slot-loading Combo drive is available as a build-to-order option. The drive can read DVD media and read and write CD media, as shown in Table 3-12.

Table 3-9 Types of media read and written by the Combo drive

Media type	Reading speed	Writing speed
DVD-ROM	8x (CAV)	–
CD-R	24x (CAV)	24x (ZCLV)
DVD+R	8x (CAV max)	
DVD+RW	8x (CAV max)	
DVD-R	8x (CAV max)	
DVD-RW	8x (CAV max)	
CD-RW	24x (CAV)	16x (ZCLV)
CD or CD-ROM	24x (CAV)	–

Important: The Combo drive supports only 12 cm disc media. It does not support 8 cm discs or noncircular media.

Digital audio signals from the Combo drive can be played through the audio outputs under the control of the Sound Manager in System Preferences.

The Combo drive is an ATAPI drive and is cable-selected as slave in an ATA device configuration.

Trackpad

The pointing device in the 17-inch PowerBook G4 is a trackpad. The trackpad is a solid-state device that emulates a mouse by sensing the motions of the user's finger over its surface and translating those motions into USB commands.

The user makes selections either by pressing the trackpad button (below the trackpad) or by tapping or double tapping on the pad itself (enabled via Systems Preferences). The trackpad responds to one or two taps on the pad itself as one or two clicks of the button. The user can tap and drag on the trackpad in much the same manner as clicking and dragging with the mouse. By default, vertical and horizontal scrolling is possible by dragging two fingers across the trackpad. The tap and double-tap functions and scrolling function are optional and can be adjusted and activated or deactivated by means of the mouse pane in System Preferences.

The trackpad on the 17-inch PowerBook G4 has palm-rejection capabilities that help prevent unintended trackpad input while typing is being performed. When the "Ignore accidental trackpad input" checkbox is selected on the keyboard and mouse pane of Systems Preferences, the system software attempts to filter out unintended contact with the trackpad. The trackpad will not respond when a mouse is present and the "Ignore accidental trackpad input" checkbox is selected on the mouse pane of Systems Preferences.

Note: If the trackpad is not responding to intended input, check to see if the "Ignore accidental trackpad input" checkbox is selected.

Keyboard

The keyboard is a full-size, 19 mm pitch, low-profile design with a row of function keys and cursor motion keys in an inverted-T arrangement. A dedicated media eject key is located to the right of the F12 function key.

The 17-inch PowerBook G4 has a backlit keyboard and ambient light sensors that control the brightness of the display and the keyboard backlighting. In low light, the computer automatically illuminates the backlit keyboard and lowers the display brightness. As light levels increase, the display brightness is re-adjusted automatically and the keyboard backlighting is turned off. There are two light sensors, one under each speaker grill.

Access to internal components and expansion connectors is no longer via the keyboard, so the keyboard is not latched for removal. Access to the memory cards is via the RAM expansion slot and is explained in "[RAM Expansion Slots](#)" (page 57).

Changing the Operation of the Keyboard

Several of the keys on the keyboard have more than one mode of operation.

- Function keys F1–F10 can also control features such the display brightness, the speaker volume, the dual display feature, the Num Lock function, and the illuminated keyboard brightness. Refer to [Table 3-10](#) (page 45) for the entire list. A media eject key is located to the right of the F12 function key.
- Certain control keys can be used as page-control keys.

- The keys on the right side of the keyboard can be used as a numeric keypad.

The next sections describe these groups of keys and the way their alternate modes of operation are selected by using the Fn key, and the Num Lock key.

Keyboard Illustrations

[Figure 3-6](#) (page 42) shows the actual appearance of the keyboard. [Figure 3-7](#) (page 43) shows the alternate modes of operation of the function and control keys. [Figure 3-8](#) (page 44) shows the embedded numeric keypad.

Figure 3-6 Keyboard layout



[Figure 3-7](#) (page 43) and [Figure 3-8](#) (page 44) include duplicate versions of some keys in order to show their alternate modes of operation. In some cases, the alternate key captions shown in the figures do not appear on the keyboard. For the actual appearance of the keyboard, refer to [Figure 3-6](#) (page 42).

Figure 3-7 Alternate operations of function and control keys

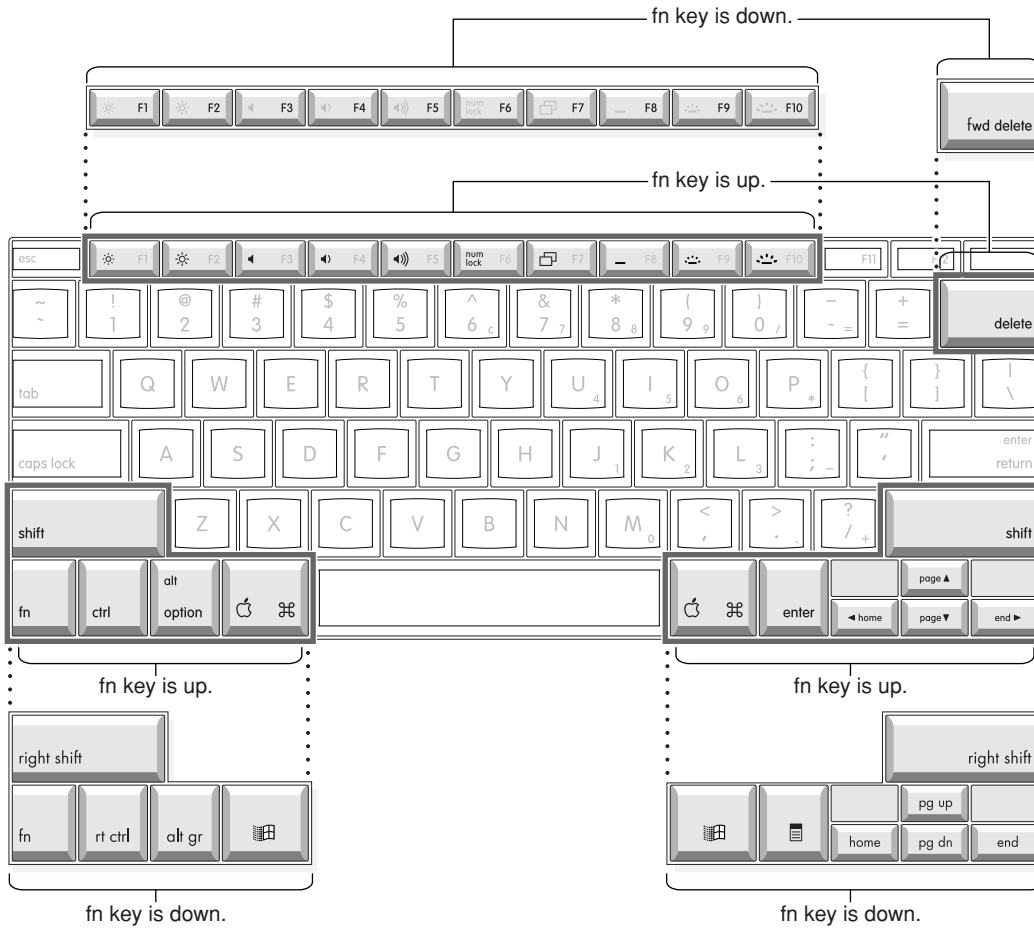
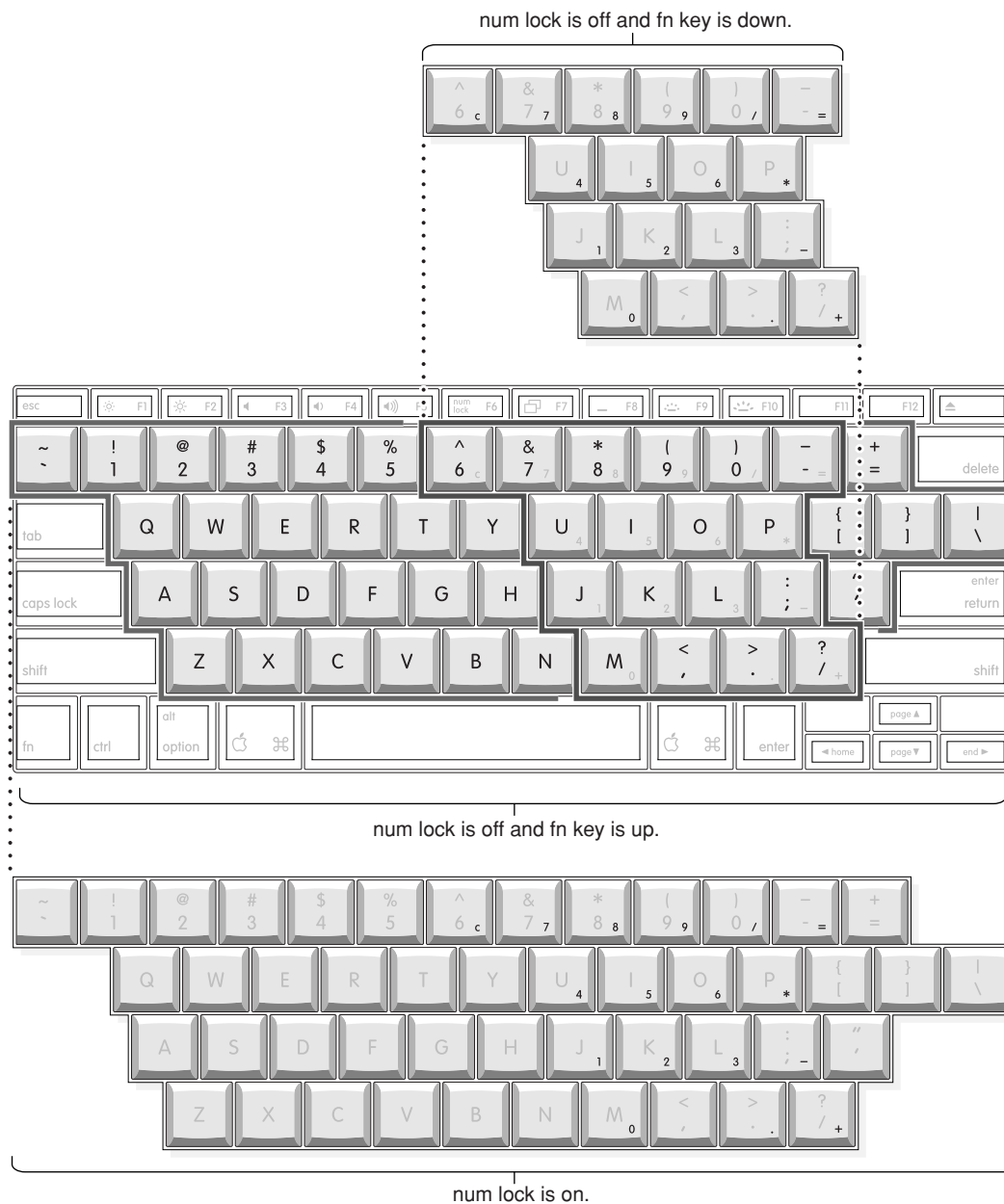

Figure 3-8 Embedded numeric keypad operation

Using the Fn Key

Pressing the Fn key affects three sets of keys: the function keys F1–F12, the embedded numeric keypad, and certain modifier keys.

- It toggles the function keys between their control-button operation and their F1–F10 functions, as shown in [Table 3-10](#) (page 45) and [Figure 3-7](#) (page 43).
- It selects the embedded numeric keypad on the right portion of the alphanumeric keys, as shown in [Table 3-11](#) (page 46) and [Figure 3-8](#) (page 44).

- It changes certain control keys, including the cursor control keys, to page control keys, as shown in [Table 3-12](#) (page 46) and [Figure 3-8](#) (page 44).

Note: In Mac OS X, a third-party utility is needed to implement user-programmable function key assignments.

Using the Num Lock Key

Pressing the Num Lock key affects two sets of keys: the embedded keypad and the rest of the alphanumeric keys.

- It selects the embedded numeric keypad, as shown in [Table 3-11](#) (page 46) and [Figure 3-8](#) (page 44).
- It makes the rest of the alphanumeric keys functionless (NOPs), as shown in [Figure 3-8](#) (page 44).

The Function Keys

[Table 3-10](#) (page 45) defines the default operation of the function keys. The "Use the F1-F12 keys for custom actions" checkbox in the Keyboard and Mouse pane in System Preferences allows you to toggle the default operation of these keys to custom actions. When this checkbox is enabled, the function keys operate as F1 through F12 keys that can be customized within individual software applications. Holding down the fn key while the checkbox is enabled, will go back to perform the default action that is listed in [Table 3-10](#) (page 45).

Table 3-10 The function keys as control buttons

Key name	Control button
F1	Decrease display brightness
F2	Increase display brightness
F3	Mute the speaker
F4	Decrease speaker volume
F5	Increase speaker volume
F6	Num Lock
F7	Switch between dual display and mirroring modes
F8*	Keyboard illumination control
F9*	Decrease keyboard illumination
F10*	Increase keyboard illumination
F11	Preset to open the Expose application (changeable in System Preferences)
F12	Preset to open the Dashboard application (changeable in System Preferences)

Key name	Control button
* Available when the ambient light is low enough to enable the backlight illumination feature.	

The Embedded Keypad

A certain group of alphanumeric keys can also function as an embedded keypad. The user selects this mode by using the Fn key or the Num Lock key. [Figure 3-8](#) (page 44) shows the keys making up the embedded keypad and [Table 3-11](#) (page 46) lists them.

Table 3-11 Embedded keypad keys

Key name	Keypad function		Key name	Keypad function
6	Clear		P	* (multiply)
7	7		J	1
8	8		K	2
9	9		L	3
0	/ (divide)		;	- (subtract)
-	= (equals)		M	0
U	4		,	NOP
I	5		.	. (decimal)
O	6		/	+ (add)

When the embedded keypad is made active by the Num Lock key, the other alphanumeric keys have no operation (NOP), as shown in [Figure 3-8](#) (page 44). The affected keys include certain special character keys: plus and equal sign, right and left brackets, vertical bar and backslash, and straight apostrophe.

Other Control Keys

The cursor control keys can also be used as page control keys. Other control keys can take on the functions of certain keys on a PC keyboard, for use with PC emulation software. The Fn key controls the modes of operation of this group of keys. [Table 3-12](#) (page 46) is a list of these keys and their alternate functions. These control keys are also shown in [Figure 3-8](#) (page 44).

Table 3-12 Control keys that change

Key name	Alternate function
Shift	Right shift key
Control	Right control key
Option	Alt gr (right Alt key)

Key name	Alternate function
Command	Windows key
Enter	Menu key (for contextual menus)
Left arrow	Home
Up arrow	Page up
Down arrow	Page down
Right arrow	End

Flat-Panel Display

The 17-inch PowerBook G4 has a built-in, wide-screen, 116 dpi, color, flat-panel, active-matrix, liquid crystal display (AMLCD) with a resolution of 1680 by 1050 pixels with an aspect ratio of 16:10 and measures 17 inches diagonally.

The display is backlit by a cold cathode fluorescent lamp (CCFL). The display uses TFT (thin-film transistor) technology for high contrast and fast response.

In addition to its native resolution the display also supports several non-native resolutions, as shown in Table 3-13. The graphics controller IC includes a scaling function that expands displays with those smaller resolutions to fill the screen.

When selecting a picture resolution with an aspect ratio of 4:3 or 16:10, the user can choose to have it displayed with square pixels and black margins on the sides, or with stretched pixels that fill the display from side to side. These options are shown in Table 3-13 (page 47).

Table 3-13 Picture sizes on the flat-panel display

Picture size	Aspect ratio	Black margins	Shape of pixels
640 by 480	4:3	yes	square
640 by 480	16:10	no	stretched
720 by 480	3:2	yes	square
720 by 480	16:10	no	stretched
800 by 500	16:10	no	square
800 by 600	4:3	yes	square
800 by 600	16:10	no	stretched
1024 by 640	16:10	no	square
1024 by 768	4:3	yes	square

Picture size	Aspect ratio	Black margins	Shape of pixels
1024 by 768	16:10	no	stretched
1152 by 720	16:10	no	square
1280 by 800	16:10	no	square
1280 by 1024	4:3	yes	square
1280 by 1024	16:10	no	stretched
1440 by 852	16:10	no	stretched
1680 by 1050	16:10	no	square

External Monitors

The computer has a Digital Visual Interface (DVI) port for connecting to flat panel displays, a VGA monitor, or projection devices. The DVI connector supports DVI-equipped displays and projectors. A DVI-to-VGA adapter is included for use with analog monitors. With a DVI-to-ADC adapter, available separately, the 17-inch PowerBook G4 can be used with any Apple flat panel display.

The computer also has an S-video-to-composite cable that supplies a video signal for an NTSC or PAL video monitor or VCR. See ["External Video Port"](#) (page 51).

Note: When a dongle is used to attach a display, connect the dongle to the display *before* plugging the dongle into the computer.

Dual Display and Mirror Mode

An external monitor or projection device connected to the computer can increase the amount of visible desktop space. This way of using an external monitor is called dual display to distinguish it from mirror mode, which shows the same information on both the external display and the built-in display. Use the F7 key to switch between the dual display mode and the mirror mode.

When mirror mode is selected, the scaling function is available on the internal display, and on the internal display and an external monitor when both are operating. However, the monitors could have black borders during mirroring, depending on the supported timings between the two displays and on the monitor's selection algorithm. Both displays show full-sized images only when the display resolution for the external monitor is set to the internal display's 1680 by 1050 native resolution. Both displays can operate with other resolution settings, but in mirror mode, one of them has a display that is smaller than the full screen and has a black border around it. With the resolution for the external monitor set to 640 by 480 or 800 by 600, the image on the internal display is smaller than its screen. For resolution settings larger than 1680 by 1050, the image on the external monitor is smaller than its screen.

Analog Monitor Resolutions

The 17-inch PowerBook G4 comes with an adapter for use with an analog video monitor. [Table 3-14](#) (page 49) lists the standard picture sizes and frame rates supported.

Table 3-14 Picture sizes on an analog monitor

Picture size (pixels)	Frame rate	Pixel depth		Picture size (pixels)	Frame rate	Pixel depth
512 by 384	60 Hz	24 bpp		1024 by 768	72 Hz	24 bpp
640 by 480	60 Hz	24 bpp		1024 by 768	75 Hz	24 bpp
640 by 480	67 Hz	24 bpp		1024 by 768	85 Hz	24 bpp
640 by 480	72 Hz	24 bpp		1152 by 870	75 Hz	24 bpp
640 by 480	75 Hz	24 bpp		1280 by 960	75 Hz	24 bpp
640 by 480	85 Hz	24 bpp		1280 by 1024	60 Hz	24 bpp
640 by 870	75 Hz	24 bpp		1280 by 1024	75 Hz	24 bpp
800 by 600	56 Hz	24 bpp		1600 by 1200	60 Hz	24 bpp
800 by 600	60 Hz	24 bpp		1600 by 1200	65 Hz	24 bpp
800 by 600	72 Hz	24 bpp		1600 by 1200	70 Hz	24 bpp
800 by 600	75 Hz	24 bpp		1600 by 1200	75 Hz	24 bpp
800 by 600	85 Hz	24 bpp		1792 by 1344	60 Hz	24 bpp
832 by 624	75 Hz	24 bpp		1856 by 1392	60 Hz	24 bpp
1024 by 768	60 Hz	24 bpp		1920 by 1440	75 Hz	24 bpp
1024 by 768	70 Hz	24 bpp		2048 by 1536	75 Hz	24 bpp

When the built-in display and an external video monitor are operating at the same time, each is allocated 64 MB of video memory. This allocation is enough to support the full 24 bit pixel depth on the built-in display running at its native resolution of 1680 by 1050 as well as a 30-inch Apple Cinema HD Display running at its native resolution of 2560 by 1600 pixels.

Digital Display Resolutions

[Table 3-15](#) (page 49) shows the resolutions supported on flat-panel (digital) displays, with pixel depths up to 24 bits per pixel.

Table 3-15 Picture sizes on a digital display

640 by 480

800 by 500
800 by 512
800 by 600
960 by 600
1024 by 600
1024 by 640
1024 by 768
1280 by 800
1280 by 1024
1344 by 840
1600 by 1200
1600 by 1200
1680 by 1050
1920 by 1200
2048 by 1280
2560 by 1600

DVI-I Connector

The external monitor connector is a DVI-I connector. It carries both digital and analog video signals. [Figure 3-9](#) (page 50) shows the contact configuration; [Table 3-16](#) (page 50) and [Table 3-17](#) (page 51) list the signals and pin assignments.

Figure 3-9 DVI-I connector

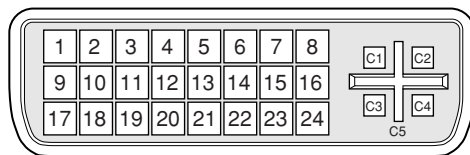

Table 3-16 Main signals on the DVI-I connector

Pin	Signal name	Pin	Signal name
1	TMDS Data2-	13	TMDS Data3+

Pin	Signal name		Pin	Signal name
2	TMDS Data2+		14	+5V Power
3	TMDS Data2/4 Shield		15	Ground for +5V Power
4	TMDS Data4–		16	Hot Plug Detect
5	TMDS Data4+		17	TMDS Data0–
6	DDC Clock		18	TMDS Data0+
7	DDC Data		19	TMDS Data0/5 Shield
8	Analog Vertical Sync		20	TMDS Data5–
9	TMDS Data1–		21	TMDS Data5+
10	TMDS Data1+		22	TMDS Clock Shield
11	TMDS Data1/3 Shield		23	TMDS Clock+
12	TMDS Data3–		24	TMDS Clock–

Table 3-17 MicroCross signals on the DVI-I connector

Pin	Signal name
C1	Analog Red Video
C2	Analog Green Video
C3	Analog Blue Video
C4	Analog Horizontal Sync
C5	Analog Common Ground Return

The graphics data sent to the digital monitor use transition minimized differential signaling (TMDS). TMDS uses an encoding algorithm to convert bytes of graphics data into characters that are transition-minimized to reduce EMI with copper cables, and DC-balanced for transmission over fiber optic cables. The TMDS algorithm also provides robust clock recovery for greater skew tolerance with longer cables or low-cost short cables. For additional information about TMDS, see the references shown in "[Digital Visual Interface](#)" (page 64).

External Video Port

The 17-inch PowerBook G4 has a video port that provides S-video output to a PAL or NTSC video monitor or VCR. The video output connector is a 7-pin S-video connector. [Figure 3-10](#) (page 52) shows the arrangement of the pins and [Table 3-18](#) (page 52) shows the pin assignments on the S-video connector.

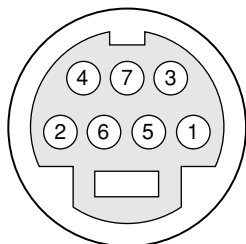
Figure 3-10 S-video connector**Table 3-18** Pin assignments for the S-video output connector

Pin number	S-video output connector
1	Analog GND
2	Analog GND
3	Video Y (luminance)
4	Video C (chroma)
5	composite video
6	Unused
7	Unused

An S-video-to-composite adapter is included and accepts an RCA plug for connecting to a composite video device.

The 17-inch PowerBook G4 provides video output at picture sizes and frame rates compatible with the NTSC and PAL standards; the picture sizes are listed in [Table 3-19](#) (page 52). Those picture sizes produce underscanned displays on standard monitors.

Table 3-19 Picture sizes for S-video output

Picture size	Pixel depth
512 by 384	24 bpp
640 by 480	24 bpp
60 Hz NTSC only 720 by 480	24 bpp
50 Hz PAL only 720 by 576	24 bpp
800 by 600	24 bpp
832 by 624	24 bpp
1024 by 768	24 bpp

Audio System

The 17-inch PowerBook G4 computer supports a audio system with both digital and analog audio. The optical digital audio input and output capability features Sony/Phillips Digital Interface (S/PDIF) input and output. S/PDIF technology results in a clean audio signal with no added noise to or from an external audio device.

Under the control of the system software, the audio circuitry digitally creates and records sounds. The 17-inch PowerBook G4 computer can receive input only from either the analog input or the digital input. However, it can output simultaneously to digital and analog devices: the internal speaker and combination the headphone out and S/PDIF out port.

By default when components are plugged into the combined optical digital audio output/headphone out port, the audio system mutes the internal speaker.

The headphones and optical digital audio output are only muted when selected in the System Preferences. Muting and audio options are set in System Preferences:Sound:Output.

The analog and digital audio circuitries are not independent. Different audio streams cannot be played to the analog and digital circuitry. The selection of digital or analog output is performed through Sound pane in System Preferences.

The audio circuitry and audio device drivers handle audio data in multiple formats. Both digital and analog audio circuitry handle audio input and output data at sample rates of 32.0 kHz, 44.1 kHz, 48.0 kHz, 64.0 kHz, 88.2 kHz, and 96.0 kHz at sample depths of 16 bits and 24 bits.

If audio data sampled from another computer at a lower rate is played as output on the 17-inch PowerBook G4, the Core Audio (Mac OS X's OS Level Audio API) transparently up-samples the data to the currently set sampling frequency prior to sending the audio data to the audio circuitry. To maximize audio fidelity, the Core Audio samples are stored as 32-bit floating point. The Sound Manager exists as a Carbon compatibility layer, but developers are encouraged to move their applications to Core Audio for maximum performance and fidelity, because the Sound Manager is capable of representing samples only as 16-bit values.

For more information about audio API's on Mac OS X, visit the Apple audio technologies developer web page at

<http://developer.apple.com/audio/>

Optical Digital Audio

The digital I/O circuitry automatically performs input clock recovery on an incoming data stream. This enables bit-accurate copies of the digital data.

Audio signals from the audio input port are converted to digital data internally. All audio is handled digitally inside the computer, including audio data from the CD or DVD drive and from devices connected to the USB and FireWire ports. Audio data is converted to analog form for output to the internal speaker, combination headphones and optical digital audio output, or external speakers.

For details on the optical digital audio input and output electrical specifications, refer to "[Audio Line In and Digital Optical Audio Input](#)" (page 55) and "[Digital Audio Output Specifications](#)" (page 56).

The 17-inch PowerBook G4 computer automatically locks its internal audio hardware to the incoming audio stream to synchronize the audio subsystem to an external device supplying the audio stream. This function allows audio and video to play in sync with the external audio or video device. The data format for signals transmitted over the optical cable is S/PDIF protocol IEC 60958-3.

Since the 17-inch PowerBook G4 does not support a hardware sample rate converter, core audio services provide the sample rate conversion.

External Clocking

When the 17-inch PowerBook G4 computer detects a digital input stream, it is automatically locked to “External” clocking and the computer audio circuitry will track and follow the outgoing digital sampling rate and lock the internal audio hardware to the sampling rate of the external device. The external clock must be stable enough to be locked onto, otherwise the digital circuit will signal an error and the driver will fall back to using the internal clock. The digital input always follows the external clock.

Internal Clocking

When the 17-inch PowerBook G4 computer is set for “Internal” clocking, the computer audio circuitry will run using the computer’s internal clock. Internal clocking is used when there is no digital input.

Audio Inputs

The audio system accepts inputs from the following sources:

- the built-in microphone
- the combined optical digital audio input/audio line in port
- a CD or DVD in the optical drive
- a digital audio device connected to a USB or FireWire port

The audio line in and optical digital audio input port and the microphone preamp share a dedicated analog input channel in the audio circuitry; the other inputs send digital data. The analog input can be set for play-through or recording. The digital inputs can be selected or mixed by the audio audio circuitry.

The computer also accepts digital audio data from the optical drive or from devices connected to the USB or FireWire ports. Audio data from those sources can be sent to the audio system to be converted to analog form for output to the speakers and the combination headphone and optical digital audio output.

Built-in Microphone

The built-in microphone is located on the left speaker grill.

The audio signal from the built-in microphone goes through a dedicated preamplifier that raises its nominal 30 mV level to a nominal 700 mV RMS signal to the audio circuitry. That signal level assures good quality digitizing without driving the analog input into clipping.

Audio Line In and Digital Optical Audio Input

The combination audio line-in and optical digital audio input is a 3.5 mm mini jack that accepts line-level stereo signals. It also accepts a stereo miniplug-to-RCA cable adapter for connecting stereo equipment to the computer.

The audio line in signal connections are

- tip: audio left channel
- ring: audio right channel
- sleeve: audio ground

Based on playback of a 1 kHz, -1dBFS 24-bit sine wave playback, 24-bit 44.1 kHz output sample rate (unless otherwise specified below) the digital audio input and output have the following electrical characteristics (nominal specifications):

- Fsi – input sample rates (external clock mode): 32 kHz, 44.1 kHz, 48 kHz, 64 kHz, 88.2 kHz, or 96 kHz
- Fsi – input sample rate (internal clock mode): 16 kHz – 96 kHz
- bits per sample: 16-bit or 24-bit
- SNR (external clock mode): >130 dB
- SNR: >110 dB
- THD+N (external clock mode): < -130 dB (0.00003%)
- THD+N: < -110 dB (0.0003%)

Modem Activity Audio Signals

Modem activity audio signals from the communications slot are sent to the audio circuitry as 8-bit digital data.

Audio Outputs

The audio system sends audio output signals to the built-in speakers and the combination optical digital audio output and headphone out port.

Note: For best results, equipment plugged into the line-out jack should not connect the audio ground to other grounds, such as the chassis or “green wire” ground.

Headphone Out

The combination headphone and optical digital audio output port is located on the left side of the computer. The headphone out provides enough current to drive a pair of low-impedance headphones. It can also be used as a line-level output.

The headphone out has the following electrical characteristics:

- impedance suitable for driving standard 32-ohm headphones
- output level 2.0 V peak-to-peak (1.41 V RMS)
- signal-to-noise (SNR) 90 dB unweighted (typical)
- total harmonic distortion (THD) 0.01% or less

Digital Audio Output Specifications

During playback of a 1KHz, full-scale sine wave (S/PDIF output format, 44.1KHz output sample rate, 24-bit sample depth, unless otherwise specified) the digital audio output has the following nominal specifications:

- Jack Type: 3.5mm Analog/Optical Combo Jack
- Output Data Formats: S/PDIF (IEC60958-3), AC3
- Output Sample Rates: 32KHz, 44.1KHz, 48KHz, 64KHz, 88.2KHz, 96KHz
- Bits per Sample: 16 or 24 (S/PDIF), 16 (AC3)
- Frequency Response: 20Hz – 20KHz, +/-0dB
- Signal-to-Noise Ratio (SNR): >130dB
- Total Harmonic Distortion + Noise (THD+N): <-130dB (0.00003%)
- Channel Separation: >130dB

Internal Speakers

The computer has two internal speakers, one on either side of the keyboard. The computer turns off the audio signals to the speakers when an external device is actively connected to the optical digital audio output and headphone out and during power management.

Digitizing Audio

The audio circuitry digitizes and records audio according to the audio input sample rate and bit depth selected in Audio MIDI setup. If a sound sampled at a higher or lower rate on another computer is played as output, the Sound Manager transparently up-samples or down-samples the sound to the audio output sample rate and bit depth selected in Audio MIDI setup prior to outputting to the audio circuitry.

When recording sound from a microphone, applications that may be affected by feedback should disable sound play-through by calling the Sound Manager functions.

Expansion Features

This chapter describes the expansion features of the 17-inch PowerBook G4's RAM expansion slots and the PC Card/CardBus slot.

RAM Expansion Slots

The 17-inch PowerBook G4 ships with 512 MB of factory-installed SDRAM. The computer has two RAM expansion slots that accommodate standard SO (small outline) DIMMs using PC2-4200 DDR2 SDRAM devices. The expansion slots are accessible for user installation of an additional SO-DIMM. Available as built to order options are 512 MB and 1 GB RAM.

The address logic for the RAM slots supports up to 2 GB total RAM. Using the highest-density devices currently available, an SO-DIMM can contain up to 1 GB of RAM, so the two RAM expansion slots can accommodate up to 2 GB total RAM.

Accessing the RAM Slots

The user can access the RAM expansion slots by removing the memory slot cover on the back of the computer, as shown in [Figure 4-1](#) (page 57). For complete instructions on accessing and replacing the RAM memory, refer to the *17-inch PowerBook G4 Getting Started* guide that came with the computer.

Figure 4-1 Removing RAM expansion slot cover

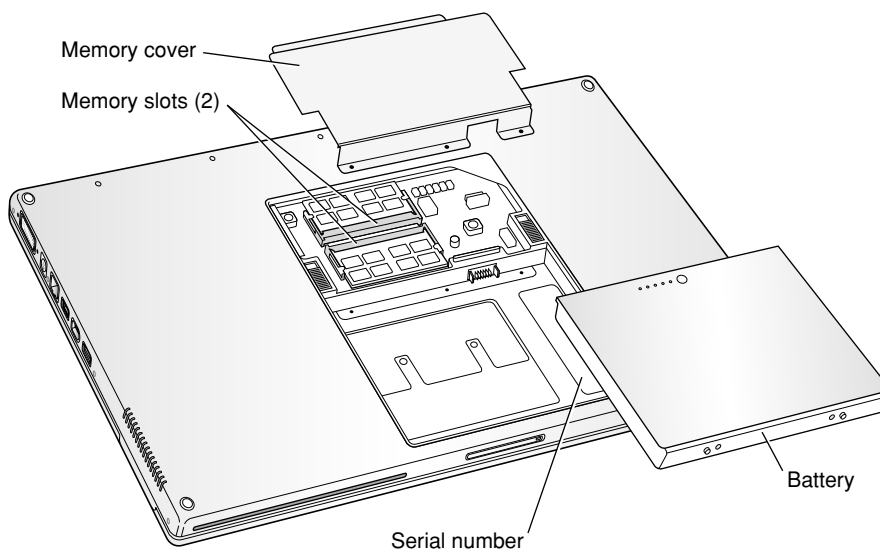

Mechanical Design of DDR2 RAM SO-DIMMs

The RAM expansion modules used in the 17-inch PowerBook G4 are PC2-4200 DDR2 SDRAM SO-DIMMs, as defined in the JEDEC specifications. The SO-DIMM runs at 333 MHz.

The mechanical characteristics of the RAM expansion SO-DIMM are given in the JEDEC specification for the DDR2 SO-DIMM. The specification number is JEDEC JESD95. To obtain a copy of the specification, see the references listed at "[RAM Expansion Modules](#)" (page 63).

The specification defines SO-DIMMs with nominal heights of 1.0, 1.25, 1.5, and 2.0 inches. The 17-inch PowerBook G4 can accommodate SO-DIMMs with heights of 1.25 inches or less.

Important: The 17-inch PowerBook G4 can not accept a 1.5 or 2-inch SO-DIMM.

Important: DDR SDRAM SO-DIMMs are keyed differently than DDR2 SDRAM SO-DIMMs and cannot be used in the 17-inch PowerBook G4.

The JEDEC specification defines the maximum depth or thickness of an SO-DIMM as 3.8 mm. Modules that exceed the specified thickness can cause reliability problems.

Electrical Design of DDR2 RAM SO-DIMMs

SO-DIMMs for the 17-inch PowerBook G4 are required to be PC2-4200 compliant. For information about the PC2-4200 specifications, see the references at "[RAM Expansion Modules](#)" (page 63).

The electrical characteristics of the DDR2 RAM SO-DIMM are given in the JEDEC specification. To obtain a copy of the specification, see the references listed at "[RAM Expansion Modules](#)" (page 63).

The JEDEC and Intel specifications define several attributes of the DIMM, including storage capacity and configuration, connector pin assignments, and electrical loading. The specifications support SO-DIMMs with either one or two banks of memory.

Important: The memory controller on the 17-inch PowerBook G4 uses separate CKE signals for each bank, as called out in the JEDEC specification. SO-DIMMs that have all the CKE pins connected together do not operate properly.

The JEDEC specification for the SO-DIMM defines a Serial Presence Detect (SPD) feature that contains the attributes of the module. SO-DIMMs for use in PowerBook computers are required to have the SPD feature.

Important: For a DIMM to be recognized by the startup software, the SPD feature must be programmed properly to indicate the timing modes supported by the DIMM.

Capacitance of the data lines must be kept to a minimum. Individual DRAM devices should have a pin capacitance of not more than 5 pF on each data pin.

DDR2 SDRAM Devices

The DDR2 SDRAM devices used in the RAM expansion modules must be self-refresh type devices for operation from a 2.5 V power supply. The data rate of the DDR2 SDRAM devices must be 333 MHz.

The devices are programmed to operate with a CAS latency of 3 or 4. At these CAS latencies, the access time from the clock transition must be +/- 0.6 ns or less for data strobes and +/- 0.7 ns for data lines. The burst length must be at least 4 and the minimum clock delay for back-to-back random column access cycles must be a latency of 1 clock cycle.

When the computer is in sleep mode, the RAM modules are in self-refresh mode and the maximum power-supply current available for each RAM module is 6 mA/128 MB (48 mA per RAM module); see the section "RAM SO-DIMM Electrical Limits " (page 60). Developers should specify DDR2 SDRAM devices with low power specifications so as to stay within that limit.

Configuration of DDR2 RAM SO-DIMMs

Table 4-1 (page 59) shows information about the different sizes of DDR2 SDRAM devices used in the memory modules.

Table 4-1 Sizes of DDR2 SDRAM expansion SO-DIMMS and devices

DIMM size	Device size	Device Configuration (depth x bits x banks)	Devices per rank	Rank size	# of ranks
256 MB	256 Mbits	8 M x 8 x 4	8	256 MB	1
512 MB	256 Mbits	8 M x 8 x 4	8	256 MB	2
512 MB	512 Mbits	8 M x 16 x 4	4	512 MB	1
512 MB	512 Mbits	16 M x 8 x 4	8	512 MB	1
1 GB	512 Mbits	8 M x 16 x 4	4	512 MB	2
1 GB	512 Mbits	16 M x 8 x 4	8	512 MB	2
1 GB	1 Gbits	8 M x 16 x 8	4	1 GB	1
1 GB	1 Gbits	16 M x 8 x 8	8	1 GB	1

Note: The 17-inch PowerBook G4 does not use memory interleaving, so installing two SO-DIMMs of the same size does not result in any performance gain.

Address Multiplexing

Table 4-2 (page 60) lists the types of devices that can be used in the 17-inch PowerBook G4.

Important: The 17-inch PowerBook G4 supports only the types of DDR2 SDRAM devices specified in [Table 4-2](#) (page 60). Other types of devices should not be used with this computer.

Table 4-2 Types of DDR2 SDRAM devices

Device size	Device configuration (depth x bits x banks)	Row address bits	Column address bits	Bank address
256 Mbits	8 M x 8 x 4	13	10	BA[0-1]
512 Mbits	8 M x 16 x 4	13	10	BA[0-1]
512 Mbits	16 M x 8x 4	14	10	BA[0-1]
1 Gbits	8 M x 16 x 8	13	10	BA[0-2]
1 Gbits	16 M x 8x 8	14	10	BA[0-2]

RAM SO-DIMM Electrical Limits

Each RAM SO-DIMM must not exceed the following maximum current limits on the 1.8 V supply:

Active: 1.2 A (8 devices at 150 mA each)

Sleep: 6 mA/128 MB (48 mA per RAM module)

Important: The restriction on sleep current is required not only to maximize the battery life but to meet the limitations of the backup battery during sleep swapping of the main battery. Developers of RAM expansion modules that exceed the limit on sleep current must include a warning to the user that battery sleep swapping may not work with those modules installed.

The Intrepid memory controller does not support 4-bit-wide SDRAM devices in any RAM expansion module.

PC Card/CardBus Slot

The PC Card/CardBus slot accepts one Type I or Type II card. The slot supports both 16-bit PC Cards and 32-bit CardBus Cards. The card can be removed and replaced while the computer is operating.

Note: The PC Card/CardBus slot does not provide 12 V power.

Supplemental Reference Documents

For more information about the technologies mentioned in this developer note, you may wish to consult some of the following references.

For information about older models of Macintosh computers, refer to the developer notes archive at

<http://developer.apple.com/documentation/Hardware/hardware2.html>

Apple Technical Notes

Apple Technical Notes answer many specific questions about the operation of Macintosh computers and the Mac OS. The notes are available on the Technical Note website at

<http://developer.apple.com/technotes/>

3D Graphics

Developers of 3D graphics for games should know about OpenGL for Macintosh[®], a new version of SGI's application programming interface (API) and software library for 3D graphics.

Information is available on the World Wide Web at

<http://www.apple.com/opengl>

Developer support and documentation is available at

<http://developer.apple.com/opengl/>

PowerPC G4 Microprocessor

Information about the PowerPC G4 microprocessor is available on the World Wide Web at

http://www.freescale.com/webapp/sps/site/prod_summary.jsp?code=MPC7447A&nodeId=018rH3bTdG8653

Velocity Engine

Velocity Engine is Apple's name for the AltiVec vector processor in the PowerPC G4 microprocessor. Apple provides support for developers who are starting to use the Velocity Engine in their applications. Documentation, development tools, and sample code are available on the World Wide Web, at

<http://developer.apple.com/hardwaredrivers/ve/index.html>

AltiVec Technology Programming Environments Manual (AltiVec PEM) is a reference guide for programmers. It contains a description for each instruction and information to help in understanding how the instruction works. Obtain a copy of the AltiVec PEM from the following Freescale site on the World Wide Web by logging in and searching for ALTIVECPEM/D.

<http://www.freescale.com/>

Mac OS X

Mac OS X is installed by default on the 17-inch PowerBook G4. For access to Apple's developer documentation for Mac OS X, see the Apple Developer Connection (ADC) website at

<http://developer.apple.com/documentation/MacOSX/MacOSX.html>

O'Reilly & Associates publishes a series of books about Mac OS X development. The books in this series have been technically reviewed by Apple engineers and are recommended by the Apple Developer Connection.

IOKit

The IOKit is part of Darwin, the operating system foundation for Mac OS X. The documentation for IOKit is available on Apple's Darwin website at

<http://developer.apple.com/documentation/Darwin/Darwin.html>

Open Firmware

The software architecture implemented on current Macintosh computers follows the standard defined by the Open Firmware IEEE 1274-1994 specification. Three Technical Notes provide an introduction to Open Firmware on the Macintosh platform. They are:

TN1061: Open Firmware, Part I, available at

<http://developer.apple.com/technotes/tn/tn1061.html>

TN1062: Open Firmware, Part II, available at

<http://developer.apple.com/technotes/tn/tn1062.html>

TN1044: Open Firmware, Part III, available at

<http://developer.apple.com/technotes/tn/tn1044.html>

Other Technical Notes provide additional information about Open Firmware on the Macintosh.

TN2000: PCI Expansion ROMs and You, at

<http://developer.apple.com/technotes/tn/tn2000.html>

TN2001: Running Files from a Hard Drive in Open Firmware, at

<http://developer.apple.com/technotes/tn/tn2001.html>

TN2004: Debugging Open Firmware Using Telnet, available at

<http://developer.apple.com/technotes/tn/tn2004.html>

RAM Expansion Modules

The mechanical characteristics of the DDR2 RAM SO-DIMM are given in JEDEC specification Standard 21-C. The DDR2 SO-DIMM specification can be found by using the search string PRN04-NM5 on the Electronics Industry Association's website at

<http://www.jedec.org/DOWNLOAD/default.cfm>

The electrical characteristics of the DDR2 RAM SO-DIMM can be found by using the search string JESD79-2A/B on the Electronics Industry Association's website at

<http://www.jedec.org/DOWNLOAD/default.cfm>

ATA Devices

ATA (AT Attachment), also referred to as integrated drive electronics (IDE), is a standard interface used with storage devices such as hard disk drives. For more information on ATA, refer to the following Apple website at

<http://developer.apple.com/documentation/Hardware/DeviceManagers/ata/ata.html>

Information about the ATA standards is available at the Technical Committee T13 AT Attachment website, at

<http://www.t13.org/>

USB Interface

For more information about USB on Macintosh computers, refer to Apple Computer's *Accessing Hardware from Applications* at

<http://developer.apple.com/documentation/Hardware/DeviceManagers/usb/usb.html>

For full specifications of the Universal Serial Bus 2.0, refer to the USB Implementers Forum on the World Wide Web, at

<http://www.usb.org/developers/docs>

FireWire Interface

For additional information about the FireWire IEEE 1394a and 1394b interfaces and the Apple API for FireWire software, refer to the resources available on the Apple FireWire website at

<http://developer.apple.com/firewire/index.html>

The IEEE 1394 standards are available from the IEEE. Ordering information can be found on the World Wide Web at

<http://shop.ieee.org/store>

You may also find useful information at the 1394 Trade Association's website:

<http://www.1394ta.org/>

Digital Visual Interface

For information about transition minimized differential signaling (TMDS) used with digital video monitors, see the specification, Digital Visual Interface DVI Revision 1.0, available on the website of the Digital Display Working Group (DDWG) at

<http://www.ddwg.org>

Wireless Networks

More information about Wi-Fi and wireless networks using the IEEE 802.11 standards is available on the website of the WiFi Alliance, at

<http://www.wirelessethernet.org/OpenSection/>

Bluetooth

For more information regarding Bluetooth technology, refer to the following locations on the World Wide Web.

Bluetooth specification:

APPENDIX A

Supplemental Reference Documents

<http://www.bluetooth.org/spec/>

Bluetooth SIG:

<http://www.bluetooth.org>

Bluetooth developer tools on the Apple web site at:

<http://developer.apple.com/hardwaredrivers/bluetooth>

Abbreviations

Here a lists of abbreviations used in this developer note.

Abbreviations and Standard Units

Standard units of measure used in this note include:

A	amperes	MB	megabytes
dB	decibels	Mbps	megabits per second
GB	gigabytes	Mbits	megabits
Hz	hertz	MHz	megahertz
KB	kilobytes	mm	millimeters
kg	kilograms	ns	nanoseconds
kHz	kilohertz	V	volts
mA	milliamperes	VDC	volts direct current
mAh	milliampere-hours		

Other Abbreviations

Other abbreviations used in this note include:

10BASE-T	an Ethernet standard for data transmission at rates up to 10 Mbits per second
100BASE-T	an Ethernet standard for data transmission at rates up to 100 Mbits per second
1000BASE-T	an Ethernet standard for data transmission at rates up to 1000 Mbits per second
AGP	accelerated graphics port
AIM	ATA Interface Module
ANSI	American National Standards Institute
API	application programming interface

ASIC	application-specific integrated circuit
ATA	AT attachment
CAS	column address strobe, a memory control signal
CD	compact disc
CD-ROM	compact disc read-only memory
CLV	constant linear velocity
CPU	central processing unit
CRT	cathode ray tube, a video display device
DAA	data access adapter (a telephone line interface)
DAC	digital-to-analog converter
DDC	display data channel
DIMM	Dual Inline Memory Module
DB-DMA	descriptor-based direct memory access
DDK	device developer's kit
DDR	double data rate, a type of SDRAM
DFS	dynamic frequency shift
DMA	direct memory access
DVI	Digital Visual Interface
EDO	extended data out
EHCI	Enhanced Host Controller Interface — USB 2.0 controller standard
EIDE	enhanced integrated device electronics
EDR	enhanced data rate
G4	Generation 4, the fourth generation of PowerPC microprocessors, incorporating AltiVec technology
GND	ground
HFS	hierarchical file system
HCRP	hardcopy cable replacement profiler
HID	human interface device, a class of USB devices
I2C	inter-IC control bus

I2S	inter-IC sound bus
IC	integrated circuit
IDE	integrated device electronics
IEC	International Electrotechnical Commission
I/O	input and output
ISM	industrial, scientific, and medicine
ISO	International Organization for Standardization
JEDEC	Joint Electron Device Engineering Council
L1	level 1 or first level, a type of CPU cache
L2	level 2 or second level, a type of CPU cache
LED	light emitting diode
Mac OS	Macintosh Operating System
MDI	Medium Dependent Interface
MDI-X	Medium Dependent Interface with Cross-Over
modem	modulator-demodulator, a data communications interface for use with analog telephone lines
NMI	nonmaskable interrupt
NOP	no operation
NVRAM	nonvolatile random-access memory
OFDM	orthogonal frequency-division multiplexing
OHCI	Open Host Controller Interface — USB 1.1 controller standard
OS	operating system
PCI	Peripheral Component Interconnect, an industry-standard expansion bus
PLL	phase-locked loop
RADIUS	Remote Authentication Dial-In User Service
RAM	random-access memory
RCA	Radio Corporation of America
rms	root mean square
ROM	read-only memory

SBP	Serial Bus Protocol
SCSI	Small Computer System Interface
SDK	software developer's kit
SDR	Single Data Rate
SDRAM	synchronous dynamic RAM
SMS	Sudden Motion Sensor
SNR	signal to noise ratio
SO-DIMM	Small Outline Dual Inline Memory Module
SPD	Serial Presence Detect, a feature of the SO-DIMM
S/PDIF	Sony/Phillips Digital Interface (digital audio I/O)
TFT	thin film transistor
TMDS	transition minimized differential signaling
USB	Universal Serial Bus, an industry-standard expansion bus
VCC	positive supply voltage (voltage for collectors)
VPN	virtual private network
WEP	Wired Equivalent Privacy
Wi-Fi	Logo used by the Wireless Ethernet Compatibility Alliance for certification of interoperability of 802.11 products
WLAN	wireless LAN
ZCLV	zone constant linear velocity

Index

Numerals

3D graphics, reference information for [61](#)

A

abbreviations [67](#)
accelerated graphics port. *See* AGP
AGP bus [23](#)
AirPort Admin Utility [35](#)
AirPort Extreme [26](#), [33–35](#)
 hardware components [34](#)
 security features [34](#)
 software components [34](#)
AirPort Extreme Application [35](#)
AirPort Extreme Base Station [34](#)
AirPort Extreme Setup Assistant [34](#)
analog audio [53](#)
ATA hard disk [35](#)
ATI Mobility Radeon 9600 IC [23](#)
audio
 digital output [56](#)

B

block diagram [20](#)
Bluetooth [26](#), [35](#), [64](#)
boot ROM [22](#)
booting from a FireWire device [31](#)
buses [19](#), [20](#), [22](#)

C

CardBus controller IC [26](#)
CardBus slot [60](#)
clock speeds [21](#)

Combo drive [40](#)
connectors
 Ethernet [32](#)
 external monitor [50](#)
 FireWire 400 [28](#)
 FireWire 800 [29](#)
 FireWire
 6-pin connector [28](#)
 9-pin connector [30](#)
 hard disk drive [37](#)
 modem [33](#)
 S-video [51](#)
 sound output jack [55](#)
 USB [27](#)

D

DDR SDRAM devices [57](#)
DFS [16](#)
digital audio [53](#)
display
 backlit [47](#)
displays
 dual mode
 resolution settings [48](#)
 external monitors [49](#)
 VGA, SVGA, and XGA monitors [49](#)
 flat panel [47](#)
 mirror mode
 resolution settings [48](#)
 scaling function [47](#)
DMA support [24](#)
dual mode
 resolution settings for [48](#)
DVD-ROM/CD-RW drive [40](#)

E

EHCI [26](#)

EIDE interface [39](#)
 Energy Star standard [17](#)
 Ethernet controller [23](#)
 Ethernet port [32](#)
 external monitors [48–51](#)
 connector [50](#)
 mirror mode with [48](#)
 pixel depths available [49](#)
 VGA, SVGA, and XGA monitors [49](#)

F

features [12](#)
 FireWire [28–32](#)
 long-haul cables [31](#)
 FireWire 400 [28](#)
 FireWire 800 [29](#)
 FireWire 800 connector [29](#)
 FireWire connectors
 6-pin connector [28](#)
 9-pin connector [30](#)
 FireWire controller [22](#)
 FireWire port
 booting from [31](#)
 Target Disk mode [31](#)
 FireWire, reference information for [64](#)
 flat panel display [47](#)

G

G4. See PowerPC G4 microprocessor
 GART [23](#)
 graphics address remapping table (GART) [23](#)
 graphics IC [23](#)

H

hard disk connector [37](#)
 pin assignments on [37](#)
 signals on [38](#)
 hard disk drive [35–39](#)
 connector
 ATA signals on [38](#)
 pin assignments on [37](#)
 dimensions and mounting holes [36](#)
 HCRP profile [35](#)
 HID profile [35](#)
 HSP profile [35](#)

I

I/O ports
 Ethernet [32](#)
 FireWire [28](#)
 USB 2.0 [27](#)
 IDE hard disk [35](#)
 internal modem [24](#)
 interrupts [24](#)

J

JEDEC specifications for SO-DIMMs [58](#)

K

keyboard [41–46](#)
 ambient light sensor [41](#)
 control keys with alternate functions [46](#)
 Fn key [44](#)
 keys with multiple functions [41](#)
 Num Lock key [45](#)

L

L2 cache [21](#)
 long-haul cables [31](#)

M

machine identification [16](#)
 memory interleaving not supported [59](#)
 microprocessor [21](#)
 microprocessor clock speeds [21](#)
 mirror mode [48](#)
 resolution settings for [48](#)
 modem [24, 33](#)
 monitor connector [50](#)

N

NTSC video monitor [51](#)

O

- OHCI 24, 26, 27
- Open Firmware 16
 - reference information for 62

P

- PAL video monitor 51
- PC Card controller IC 26
- PCI USB 2.0 controller 26
- peripheral devices 15
- pointing device 41
- power controller IC 25
- power management 16
 - processor 17
 - system 16
- power saving modes 25
- power saving states 16
- PowerPC G4 microprocessor 21
- processor power management 17

R

- RAM expansion 57–60
 - DDR SDRAM device specifications 59
 - maximum current limits 60
 - memory interleaving not supported 59
 - module sizes 59
 - sizes of SO-DIMMs 57
- RAM expansion module
 - capacities 59
- ROM. *See* boot ROM

S

- S-video connector 51
- S/PDIF digital audio 56
- S/PDIF digital audio 53
- scaling of display images 47
- SDRAM devices
 - specifications of 59
- serial presence detect, on SO-DIMM 58
- sleep state 16
- SO-DIMMs DDR 57
- SO-DIMMs
 - address multiplexing on 59
 - configurations 59

- DDR SDRAM device specifications 59
- electrical design of 58
- electrical limits for 60
- mechanical design of 58
- serial presence detect on 58
- sound circuitry 24
- sound system 53–56
 - input sources 54
 - built-in microphone 54
 - external input 55
 - internal speakers 56
 - output devices 55
- speakers 56
- Sudden Motion Sensor 13, 26
- SuperDrive 12, 39, 40
- SVGA monitors 49
- system software 16
 - idle state 16
 - machine identification 16
 - Open Firmware 16
 - sleep state 16

T

- Target Disk mode 31
- trackball 41
- trackpad 41

U

- Ultra ATA-100 bus 35
- units of measure 67
- Universal Serial Bus. *See* USB ports
- USB 1.1 24
- USB 2.0 26
 - USB 2.0 connectors 27
 - USB 2.0 ports 27–28
 - connectors 27
- USB controller IC 26
- USB ports
 - data transfer speeds 26, 28
- USB, reference information for 63

V

- VGA monitors 49
- video display
 - controller IC 23
 - subsystem architecture 23

video monitors [49](#)
 See also external monitors
video port [51](#)

W

wireless LAN module [26](#)
wireless LAN module. *See* AirPort Extreme

X

XGA monitors [49](#)