Mac mini Developer Note

[Hardware & Drivers](#) > [Apple Hardware](#)



2005-04-05



Apple Inc.
© 2005 Apple Computer, Inc.
All rights reserved.

No part of this publication may be reproduced, stored in a retrieval system, or transmitted, in any form or by any means, mechanical, electronic, photocopying, recording, or otherwise, without prior written permission of Apple Inc., with the following exceptions: Any person is hereby authorized to store documentation on a single computer for personal use only and to print copies of documentation for personal use provided that the documentation contains Apple's copyright notice.

The Apple logo is a trademark of Apple Inc.

Use of the "keyboard" Apple logo (Option-Shift-K) for commercial purposes without the prior written consent of Apple may constitute trademark infringement and unfair competition in violation of federal and state laws.

No licenses, express or implied, are granted with respect to any of the technology described in this document. Apple retains all intellectual property rights associated with the technology described in this document. This document is intended to assist application developers to develop applications only for Apple-labeled computers.

Every effort has been made to ensure that the information in this document is accurate. Apple is not responsible for typographical errors.

Apple Inc.
1 Infinite Loop
Cupertino, CA 95014
408-996-1010

Apple, the Apple logo, AirPort, AirPort Extreme, FireWire, iChat, iPod, iSight, Mac, Mac OS, Macintosh, QuickTime, SuperDrive, and Velocity Engine are trademarks of Apple Inc., registered in the United States and other countries.

DEC is a trademark of Digital Equipment Corporation.

OpenGL is a registered trademark of Silicon Graphics, Inc.

PowerPC and the PowerPC logo are trademarks of International Business Machines Corporation, used under license therefrom.

Simultaneously published in the United States and Canada.

Even though Apple has reviewed this document, APPLE MAKES NO WARRANTY OR REPRESENTATION, EITHER EXPRESS OR IMPLIED, WITH RESPECT TO THIS DOCUMENT, ITS QUALITY, ACCURACY, MERCHANTABILITY, OR FITNESS FOR A PARTICULAR PURPOSE. AS A RESULT, THIS DOCUMENT IS PROVIDED "AS IS," AND YOU, THE READER, ARE ASSUMING THE ENTIRE RISK AS TO ITS QUALITY AND ACCURACY.

IN NO EVENT WILL APPLE BE LIABLE FOR DIRECT, INDIRECT, SPECIAL, INCIDENTAL, OR CONSEQUENTIAL DAMAGES RESULTING FROM ANY DEFECT OR INACCURACY IN THIS DOCUMENT, even if advised of the possibility of such damages.

THE WARRANTY AND REMEDIES SET FORTH ABOVE ARE EXCLUSIVE AND IN LIEU OF ALL OTHERS, ORAL OR WRITTEN, EXPRESS OR IMPLIED. No Apple dealer, agent, or employee is authorized to make any modification, extension, or addition to this warranty.

Some states do not allow the exclusion or limitation of implied warranties or liability for incidental or consequential damages, so the above limitation or exclusion may not apply to you. This warranty gives you specific legal rights, and you may also have other rights which vary from state to state.

Contents

Introduction **Introduction to Mac mini Developer Note** 9

Organization of This Document 9

Chapter 1 **Overview to the Mac mini** 11

Features 11
Enclosure 12
System Software 13
 Computer Identification 13
 NMI without Programmer's Switch 13
 Velocity Engine Acceleration 14

Chapter 2 **Architecture** 15

Block Diagram and Buses 15
 Block Diagram 15
 Main ICs and Buses 16
Microprocessor and Cache 17
 PowerPC G4 Microprocessor 17
 Level 2 Cache 17
Memory and I/O Device Controller 17
 System RAM 18
 Video Display Subsystem 18
 Boot ROM 18
 Ethernet Controller 18
 FireWire 400 Controller 19
 Ultra ATA/100 Interface 19
 Modem Support 19
 Bluetooth Technology 19
 Power Controller 19
 Sound Circuitry 20
 AirPort Extreme Wireless Support 20
 USB Interface 20

Chapter 3 **Devices and Ports** 21

USB Ports 21
 USB Connectors 21
 USB Features 22
FireWire 400 Port 22
 FireWire Device Programming 23

- FireWire 400 Connector 23
- Target Disk Mode 24
- Ethernet Port 25
- Internal Modem 26
- AirPort Extreme Card 26
 - Data Security 26
 - AirPort Extreme Hardware 27
 - AirPort Extreme Software 27
- Bluetooth Technology 27
- Hard Disk Drive 28
- Combo Drive 28
- SuperDrive 29
- DVI Port 29
- DVI to Video Adapter 31
- Sound System 32
 - Sound Input 32
 - Sound Output 32
 - Audio CODEC 33

Chapter 4 RAM Expansion 35

- RAM Expansion 35
- RAM Expansion Modules 35
 - Mechanical Design of RAM DIMMs 35
 - Electrical Design of RAM DIMMs 35

Appendix A Supplemental Reference Documents 37

- Apple Technical Notes 37
- 3D Graphics 37
- PowerPC G4 Microprocessor 37
- Velocity Engine (AltiVec) 37
- Mac OS X 38
- I/O Kit 38
- Open Firmware 38
- RAM Expansion Modules 39
- ATA Devices 39
- USB Interface 39
- Ethernet 40
- FireWire Interface 40
- Digital Visual Interface 40
- Wireless Networks 41
- Bluetooth 41

Appendix B **Abbreviations 43**

Index 47

Figures and Tables

Chapter 1 **Overview to the Mac mini 11**

Figure 1-1 Mac mini Enclosure 12

Chapter 2 **Architecture 15**

Figure 2-1 Block diagram 16

Table 2-1 Bus speeds 17

Chapter 3 **Devices and Ports 21**

Figure 3-1 USB Type A port and pins 21

Figure 3-2 FireWire 400 connector 24

Figure 3-3 DVI connector 30

Figure 3-4 S-video connector 31

Table 3-1 Signals on the USB port 21

Table 3-2 Signals on the FireWire 400 connector 24

Table 3-3 Signals on the Ethernet connector 25

Table 3-4 Types of media read and written by the Combo drive 28

Table 3-5 Types of media read and written by the SuperDrive 29

Table 3-6 Signals on the DVI connector 30

Table 3-7 Pin assignments for the S-video output connector 31

Table 3-8 Desktop sizes for S-video output 32

Chapter 4 **RAM Expansion 35**

Table 4-1 Sizes of DDR SDRAM expansion DIMMS and devices 36

Introduction to Mac mini Developer Note

This developer note gives a technical description of the Mac mini. The note provides information about the computer's internal design, input-output features, and expansion capabilities.

This developer note is intended to help hardware and software developers design products that are compatible with the products described here. If you are not already familiar with Macintosh computers or if you would simply like additional technical information, refer to [Appendix A, "Supplemental Reference Documents"](#) (page 37) for details

Organization of This Document

The information in this note is arranged in four chapters and two appendixes.

- [Chapter 1, "Overview to the Mac mini"](#) (page 11) introduces the Mac mini, describes its features, and mentions a few software issues of interest to developers.
- [Chapter 2, "Architecture"](#) (page 15) describes the internal organization of the computer. It includes a functional block diagram and descriptions of the main components on the logic board.
- [Chapter 3, "Devices and Ports"](#) (page 21) describes the I/O ports and the built-in I/O devices.
- [Chapter 4, "RAM Expansion"](#) (page 35) includes development guidelines for the RAM expansion modules.
- [Appendix A, "Supplemental Reference Documents"](#) (page 37) provides sources of additional information about the technologies used in the Mac mini.
- [Appendix B, "Abbreviations"](#) (page 43) lists standard units of measure and other abbreviations used in this developer note.

INTRODUCTION

Introduction to Mac mini Developer Note

Overview to the Mac mini

This chapter lists the features of the new Mac mini and provides information about a few software issues of interest to developers. The Mac mini does not ship with a monitor, keyboard, or mouse.

Features

- **Microprocessor:** The Mac mini has a PowerPC G4 microprocessor running at a clock speed of 1.25 GHz or 1.42 GHz. For more information, see [“PowerPC G4 Microprocessor”](#) (page 17).
- **Memory:** The computer comes with 256 MB of DDR333 (PC2700) SDRAM installed in an internal 184-pin DIMM expansion slot, with build-to-order options of 512 MB and 1 GB. The maximum supported memory is 1 GB. For more information, see [“RAM Expansion Modules”](#) (page 35).
- **Graphics:** The video circuits provide built-in 2D and 3D acceleration using an ATI Radeon 9200 graphics processor with 32 MB 190 MHz DDR memory. For more information, see [“Video Display Subsystem”](#) (page 18).
- **Main memory bus:** The speed of the memory bus is 167 MHz. For more information, see [“Main ICs and Buses”](#) (page 16).
- **Cache:** The 512 KB on-chip L2 cache is included on the microprocessor IC and has the same clock speed as the microprocessor. For more information, see [“Level 2 Cache”](#) (page 17).
- **Hard disk storage:** The built-in hard disk drive has a capacity of 40 GB or 80 GB, with an 80 GB build-to-order option. For more information, see [“Hard Disk Drive”](#) (page 28).
- **Combo drive:** The Mac mini has a combination DVD-ROM/CD-RW drive. For more information, see [“Combo Drive”](#) (page 28).
- **SuperDrive :** A SuperDrive (CD-RW/DVD-R) is available as a build-to-order option. For more information, see [“SuperDrive”](#) (page 29).
- **External video monitor:** The Mac mini has a DVI port and includes a DVI to VGA adapter. A video adapter with composite and S-video connectors is available separately. For more information, see [“DVI to Video Adapter”](#) (page 31).
- **Video RAM:** The video hardware includes 32 MB of DDR video memory, which supports 3D features and millions of colors in all resolutions. For more information, see [“Video Display Subsystem”](#) (page 18) and [“DVI Port”](#) (page 29).
- **USB ports:** The Mac mini has two USB 2.0 ports. For more information, see [“USB Ports”](#) (page 21).
- **FireWire 400 ports:** The Mac mini has one IEEE-1394a FireWire 400 port supporting transfer rates of 100, 200, and 400 Mbps. For more information, see [“FireWire 400 Port”](#) (page 22).
- **Target Disk Mode:** The computer can act like a FireWire storage device connected to another computer. See [“Target Disk Mode”](#) (page 24).
- **Modem:** The Mac mini has a built-in fax modem with a V.92 56 Kbps data rate; an optional to configure without a modem is available. For more information, see [“Internal Modem”](#) (page 26).

- **Ethernet:** The Mac mini has a built-in Ethernet port for a 10Base-T and 100Base-T operation. For more information, see “[Ethernet Port](#)” (page 25).
- **AirPort Extreme Card:** An internal AirPort Extreme Card wireless LAN module is available as a build-to-order option. For more information, see “[AirPort Extreme Card](#)” (page 26).
- **Bluetooth:** Fully-integrated Bluetooth is available as a build-to-order option to enable short-range wireless connections between desktop and laptop computers and a host of other peripheral devices. For more information, see “[Bluetooth Technology](#)” (page 19).
- **Sound:** The Mac mini has an internal speaker with amplifier and a headphone/audio line-out jack. For more information, see “[Sound System](#)” (page 32).
- **Power source:** The primary power source is an 85 W, 18.5 V power adapter.
- **Size and weight:** The Mac mini is 2 inches (5.08 cm) high, 6.5 inches (16.51 cm) wide, and 6.5 inches (16.51 cm) deep; it weighs 2.9 pounds (1.32 kg).

Enclosure

Figure 1-1 (page 12) shows the front and rear views of the Mac mini.

Figure 1-1 Mac mini Enclosure

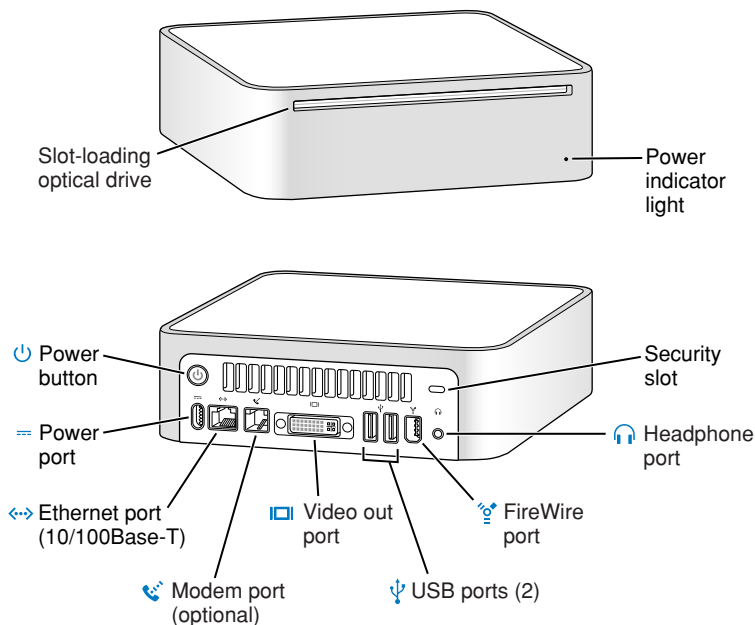

System Software

The Mac mini comes with Mac OS X version 10.3.7 or later installed as the default system. Mac OS 9 applications can be run in Classic mode. Install the Classic environment from the “Additional Hardware and Apple Software Test” CD shipped with your computer. For more information about Mac OS X, see the reference listed in “[Mac OS X](#)” (page 38).

Computer Identification

Rather than reading the box flag or the model string and then making assumptions about the computer’s features, applications that need to find out the features of the computer should use IORegistry calls to test for the features they require. IORegistry calls are part of the I/O Kit API. For more information, see the references listed at “[I/O Kit](#)” (page 38).

Asset management software that reports the kind of computer it is run on can obtain the value of the model property from the IOService plane of the IORegistry. For the Mac mini, the value of the string in the `compatible` property is `PowerMac10,1`.

NMI without Programmer’s Switch

Current Macintosh computers do not have a programmer’s switch, which allowed users to generate a non-maskable interrupt (NMI). The paragraphs below describe how to generate an NMI from a remote session for systems that do not have a physical programmer’s switch.

Starting with Mac OS X 10.1.2, the OS will promote and recognize the `DB_NMI` bit in the debug parameter of the “boot-args” property from Open Firmware. When the `DB_NMI` bit is set, the user can generate a non-maskable interrupt (NMI) by pressing the system’s power button. This replaces the power button’s sleep or wake response. The system reads the state of the bit at boot time from the `boot-args` configuration variable. For more information about the debug flags, please see *Inside Mac OS X: Kernel Programming*.

To set the `DB_NMI` bit, enter the following command at the Terminal to display the current debug flag settings.

```
% nvram boot-args
```

Add the parameter `debug=0x4`, as follows.

```
% sudo nvram boot-args="<current settings> debug=0x4"
```

After the `DB_NMI` bit in the debug parameter is set, reboot the machine. After reboot, pressing the power button for approximately 1 second will generate an NMI.

Note: If the power button is pressed for more than five seconds, the system will immediately power off.

The power button will retain this functionality until Mac OS X is restarted without the `DB_NMI` bit set. To clear this bit, issue the `nvram` command omitting `debug=0x4` parameter, as follows, then restart the machine.

```
% sudo nvram boot-args=""
```

Note: The debug flags bit will be cleared if you use System Preferences to change the startup disk. It may also be cleared if you perform an installation that requires a restart.

Velocity Engine Acceleration

The Velocity Engine (an implementation of AltiVec) is the vector processing unit in the PowerPC G4 microprocessor. Some system software has been modified to take advantage of the accelerated processing that the Velocity Engine makes possible. System software has also been modified to support low-level operations using the Velocity Engine.

For complete information on the Velocity Engine, refer to the following Apple website:

<http://developer.apple.com/hardwaredrivers/ve/index.html>

Architecture

This chapter describes the architecture of the Mac mini. It includes information about the major components on the main logic board: the microprocessor, the other main ICs, and the buses that connect them to each other and to the I/O interfaces.

Block Diagram and Buses

This section is an overview of the major ICs and buses on the computer's main logic board.

Block Diagram

[Figure 2-1](#) (page 16) is a simplified block diagram of the main logic board. The diagram shows the main ICs and the buses that connect them together.

Figure 2-1 Block diagram

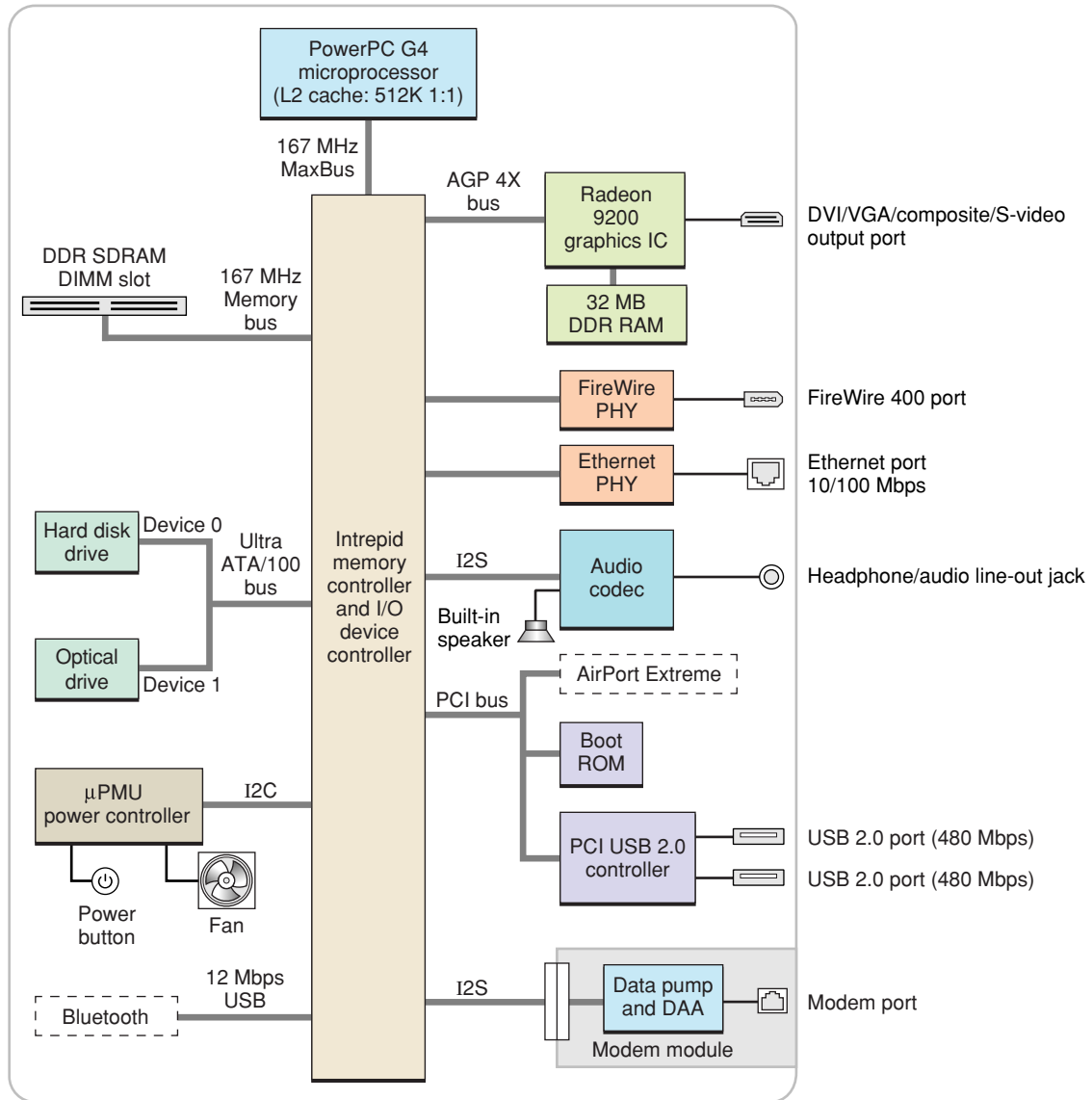

Main ICs and Buses

The architecture of Mac mini is designed around the PowerPC G4 microprocessor and the Intrepid memory and I/O device controller. The Intrepid occupies the center of the block diagram.

The MaxBus connects the PowerPC G4 microprocessor to the Intrepid ASIC. The MaxBus has 64 data lines, 32 address lines, and a bus clock speed of 167 MHz. The Intrepid ASIC has other buses that connect with the boot ROM, the hard disk drive, and the optical drive, the power controller IC, the sound IC, the internal modem module, and the optional wireless LAN module.

The Intrepid I/O controller has a 32-bit PCI bus with a bus clock speed of 33 MHz.

Each of the components listed here is described in one of the following sections.

Microprocessor and Cache

The microprocessor is a 1.25 GHz or 1.42 GHz PowerPC G4 with a built-in level 2 (L2) cache.

PowerPC G4 Microprocessor

The PowerPC G4 microprocessor used in the Mac mini has many powerful features, including.

- 32-bit PowerPC implementation
- superscalar PowerPC core
- Velocity Engine (AltiVec technology): 128-bit wide vector execution unit
- pipelined, high bandwidth system bus, called MaxBus
- dual 32 KB instruction and data caches (level 1)
- built-in 512 KB on-chip L2 cache

To find more information, see the reference at [“PowerPC G4 Microprocessor”](#) (page 37).

Level 2 Cache

The data storage for the L2 cache consists of 512 KB of fast static RAM that is built into the microprocessor chip along with the cache controller. The built-in L2 cache runs at the same clock speed as the microprocessor.

Memory and I/O Device Controller

The Intrepid ASIC combines several functions into a single IC. The IC contains the memory controller, the PCI bus bridge, the Ethernet and FireWire 400 interfaces, the USB 1.1 interface, and the AGP interface.

In addition to the buses listed in [Table 2-1](#) (page 17), the Intrepid ASIC also has separate interfaces to the physical layer (PHY) ICs for Ethernet and FireWire 400 and an I2C interface that is used for configuring the memory subsystem.

Table 2-1 Bus speeds

Name of bus	Destinations	Width of data path	Bus clock speed/ data rate
MaxBus	Microprocessor	64 bits	167 MHz
Memory bus (DDR)	System RAM	64 bits	167 MHz (2x)
AGP 4x bus	Graphics IC	32 bits	66 MHz (4x)
Ultra ATA -100 bus (device 0)	Hard drive	16 bits	100 MBps
Ultra ATA -100 bus (device 1)	Optical drive	16 bits	33 MBps

The Intrepid ASIC provides DB-DMA (descriptor-based direct memory access) support for the I/O channels. The DBDMA system provides a scatter-gather process based on memory resident data structures that describe the data transfers. The DMA engine is enhanced to allow bursting of data files for improved performance.

The following sections describe the subsystems that are connected to the Intrepid ASIC.

System RAM

The memory subsystem in the Mac mini consists of 256 MB of DDR333 (PC2700) SDRAM in one of the DIMM slot. The data bus to the RAM is 64 bits wide, and the memory interface is synchronized to the MaxBus interface at 167 MHz. The system supports a maximum of 1 GB.

Note: Additional memory can be installed as a build-to-order option or by an Authorized Apple Service Provider.

For more information on system RAM, see [“RAM Expansion”](#) (page 35).

Video Display Subsystem

The display subsystem consists of a graphics controller IC and 32 MB of DDR on the main logic board. The graphics controller IC is an ATI Radeon 9200. It contains 2D and 3D acceleration engines, front-end and back-end scalers, a CRT controller, and an AGP bus interface with bus master capability.

The interface between the graphics IC and the rest of the system is a 4x AGP (accelerated graphics port) bus on the Intrepid IC. To give the graphics IC fast access to system memory, the AGP bus has separate address and data lines and supports deeply pipelined read and write operations. The AGP bus has 32 data lines and a clock speed of 66 MHz.

The graphics IC uses a graphics address remapping table (GART) to translate AGP logical addresses into physical addresses. The graphics driver software can allocate memory in both the dedicated SDRAM and the main memory.

For information about the display and supported resolutions, see [“DVI Port”](#) (page 29).

Boot ROM

The boot ROM is a 1 M by 8 bit device and is connected to the Intrepid ASIC by way of the high byte of the PCI bus plus three additional control signals: chip select, write enable, and output enable.

Ethernet Controller

The Mac mini includes an ethernet media access controller (MAC) that implements the Link layer. The Intrepid ASIC provides DB-DMA support for the Ethernet interface.

The controller is connected by a PCI bus to a PHY interface IC that is capable of operating in either 10-BaseT or 100-BaseT mode. The actual speed of the link is automatically negotiated by the PHY and the bridge or router to which it is connected. For information about the port, see [“Ethernet Port”](#) (page 25).

FireWire 400 Controller

The Mac mini includes an IEEE 1394a FireWire 400 controller with a maximum data rate of 400 Mbps (50MBps). The Intrepid IC provides DMA (direct memory access) support for the FireWire interface. The FireWire 400 controller complies with the Open Host Controller Interface (OHCI) specification.

The controller IC implements the FireWire link layer. A physical layer IC, called a PHY, implements the electrical signalling protocol of the FireWire interface.

Ultra ATA/100 Interface

The Ultra ATA/100 interface supports the hard disk drive as the master device 0 and the optical drive as the slave device 1. The Apple System Profiler identifies these devices as device 0 and device 1.

The Ultra ATA/100 interface complies with and supports a subset of industry standard ATA/ATAPI-6 and transfer protocols up to ultra DMA mode 5. For more information, see [“Hard Disk Drive”](#) (page 28), [“Combo Drive”](#) (page 28) and [“SuperDrive”](#) (page 29).

Modem Support

The internal modem is connected to an internal I2S interface. The modem provides digital call progress signals to the sound circuitry. The analog side of the connection gets power from the phone line; the digital side gets power from the Mac mini. The modem is optional on the education configuration.

The modem is a separate module that contains the datapump and the interface to the telephone line (DAA). For more information about the modem, see [“Internal Modem”](#) (page 26).

Bluetooth Technology

Bluetooth is an open specification that enables short-range wireless connections between desktop and laptop computers and a host of other peripheral devices. Bluetooth is available as an internal build-to-order option or as an Apple Authorized Service Provider upgrade. When the Bluetooth option is installed, the Bluetooth antenna is built into the system.

For more information on Bluetooth technology, refer to [“Bluetooth Technology”](#) (page 27).

Power Controller

The power management controller in the Mac mini is a custom IC called the uPMU. The uPMU combines the functions of power management and fan control into one component.

Sound Circuitry

The sound circuitry is connected to the Intrepid IC by standard IIC and IIS buses. The IIC bus provides configuration access to the audio circuitry ICs and the IIS bus is used for data transfers. The Intrepid IC provides DB-DMA (descriptor-based direct memory access) support for the IIS port.

The audio circuitry performs digital audio processing and codec functions. The audio processing functions include output equalization and volume control. The codec functions include A-to-D and D-to-A conversion.

Audio data from the Intrepid IC drives the audio circuitry's D-to-A converter. Analog output from the D-to-A converter is routed to the headphone jack and the audio power amplifier. The internal speaker is driven with a left/right blender and power amplifier. When headphones are connected to the headphone jack, the internal speaker is muted.

For a description of the features of the sound system, see ["Sound System"](#) (page 32).

AirPort Extreme Wireless Support

Apple's internal wireless LAN module, the 54 Mbps AirPort Extreme Card, is available as a build-to-order option or as an Apple Authorized Service Provider upgrade. The connector for the AirPort Extreme Card uses the PCI bus. When the AirPort Extreme option is installed, the AirPort antenna is built into the system. For information about operation, see ["AirPort Extreme Card"](#) (page 26).

USB Interface

The Intrepid ASIC has three USB 1.1 controllers, numbered 0, 1, and 2. Port 2 is used by Bluetooth and ports 0 and 1 are not available for use.

The Mac mini uses a PCI USB 2.0 controller to support two external ports that support USB 2.0 and 1.1 devices with data transfer rates of 480 Mbps, 12 Mbps, or 1.5 Mbps.

USB devices connected to the Mac mini are required to support USB-suspend mode as defined in the USB specification.

The USB ports on the Mac mini comply with the Universal Serial Bus Specification 2.0. The USB 2.0 controllers comply with the Enhanced Host Controller Interface (EHCI) specification.

For more information about USB, see ["USB Ports"](#) (page 21). For USB reference information, see ["USB Interface"](#) (page 39).

Devices and Ports

This chapter describes both the built-in I/O devices and the ports for connecting external I/O devices. Each of the following sections describes an I/O port or device.

USB Ports

The Mac mini has two external Universal Serial Bus (USB) ports for connecting a keyboard, mouse, or additional I/O devices such as printers, scanners, and storage devices. The USB 2.0 ports are connected to a discrete USB 2.0 controller chip. The optional Bluetooth module is connected to the Intrepid ASIC via an internal USB 1.1 connection. See “[USB Interface](#)” (page 39) for reference information.

For more information about USB on Macintosh computers, please refer to sources listed in “[USB Interface](#)” (page 39).

USB Connectors

The USB ports use USB Type A connectors, which have four pins each. Two of the pins are used for power and two for data. [Figure 3-1](#) (page 21) is an illustration of a Type A port; [Table 3-1](#) (page 21) shows the signals and pin assignments.

Figure 3-1 USB Type A port and pins

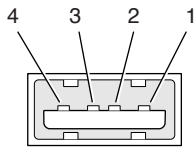

Table 3-1 Signals on the USB port

Pin	Signal name	Description
1	VCC	+5 VDC
2	D-	Data -
3	D+	Data +
4	GND	Ground

The Mac mini provides 5 volt power to the USB ports. The maximum current available is 500 mA on each port.

The external USB 2.0 ports support low-speed (1.5 Mbps), full-speed (12 Mbps), and high-speed (480 Mbps) data transfers. High-speed operation requires the use of shielded cables.

The Macintosh system software supports all four data transfer types defined in the USB specification.

USB Features

Features of the USB ports include the following sections.

Note: When powered-off or in sleep mode, the USB port does not receive power.

Wake Up From Sleep

USB devices can provide a remote wakeup function for the computer. The USB root hub in the computer is set to support remote wakeup whenever a device is attached to or disconnected from the bus. The keyboard that comes with the computer uses this method to wake the computer on a key press.

Connect and Resume

The Intrepid ASIC contains special circuitry that allows the computer to wake from sleep mode on connect, disconnect, and resume events. Compatible USB devices should support the USB-suspend mode defined in the USB specification.

USB Device Drivers

Class drivers are software components that are able to communicate with many USB devices of a particular kind. If the appropriate class driver is present, any number of compliant devices can be plugged in and start working immediately without the need to install additional software. The Mac OS for the Mac mini supports USB Mass Storage specification.

USB Controller

The Mac mini uses Open Host Controller Interface (OHCI) controller for USB communication. Some early USB devices (most notably keyboards) can't interoperate with an OHCI controller. Those devices are not supported by the Macintosh USB system software. The USB 2.0 controllers comply with the Enhanced Host Controller Interface (EHCI) specification.

FireWire 400 Port

The Mac mini has one external FireWire 400 IEEE 1394a port. The features of the FireWire port are:

- Support serial I/O at 100, 200, and 400 Mbps (megabits per second)
- Up to 8 watts of power when the computer system is on
- Support up to 62 devices

- The FireWire port receives power whenever the system is plugged in.

The FireWire hardware and software provided with the Mac mini are capable of all asynchronous and isochronous transfers defined by the IEEE 1394a standard.

FireWire Device Programming

Mac OS X includes general support for the FireWire bus and specific support for various kinds of FireWire devices and protocols. Developers can use the built-in support or provide additional applications and drivers for use with their products.

The general FireWire services will configure the FireWire bus, scan the bus for new devices, and allow multiple drivers and devices to share a single FireWire interface cooperatively. The general services also publish information about the bus and the devices in the IO Registry, so that IO Kit can match protocols and drivers to each connected FireWire device.

The specific device and protocol support in Mac OS X as provided with the Mac mini includes the following:

- General services for Serial Bus Protocol 2 (SBP-2) and support for most mass storage devices using SBP-2, such as hard disk drives, optical drives, flash card readers, Target Disk Mode (see “[Target Disk Mode](#)” (page 24)), and the iPod. Mac OS X can boot from most of these devices.
- General services for the Audio Video Control (AV/C) protocol and support for most digital video (DV) cameras and decks using this protocol, including video capture through standard QuickTime APIs.
- A QuickTime device driver for IIDC/DCAM type cameras such as the iSight.
- A network device driver supporting IP (Internet Protocol) over FireWire according to IEEE RFC 2734.
- Additional services for user-space and kernel access to all FireWire resources.

For information on writing FireWire drivers or applications, download the latest FireWire SDK from <http://developer.apple.com/sdk/>

For additional references, refer to “[FireWire Interface](#)” (page 40).

FireWire 400 Connector

The FireWire 400 connector has six contacts, as shown in [Figure 3-2](#) (page 24). The connector signals and pin assignments are shown in [Table 3-2](#) (page 24).

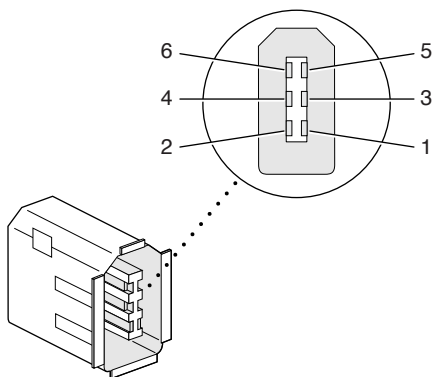
Figure 3-2 FireWire 400 connector**Table 3-2** Signals on the FireWire 400 connector

Pin	Signal name	Description
1	Power	unregulated DC; 17-24 V no load
2	Ground	Ground return for power and inner cable shield
3	TPB-	Twisted-pair B, differential signals
4	TPB+	Twisted-pair B, differential signals
5	TPA-	Twisted-pair A, differential signals
6	TPA+	Twisted-pair A, differential signals
Shell	—	Outer cable shield

When the computer is on, the power pin provides a maximum voltage of 18.5 V (no load) and up to 8 W total power.

The FireWire PHY is powered as long as the computer is connected to AC power.

Pin 2 of the 6-pin FireWire connector is ground for both power and inner cable shield. If a 4-pin connector is used on the other end of the FireWire cable, its shell should be connected to the wire from pin 2.

The signal pairs are crossed in the cable itself so that pins 5 and 6 at one end of the cable connect with pins 3 and 4 at the other end. When transmitting, pins 3 and 4 carry data and pins 5 and 6 carry clock; when receiving, the reverse is true.

For additional information about the FireWire interface and the Apple APIs for FireWire device control, developers should refer to the resources listed in [“FireWire Interface”](#) (page 40).

Target Disk Mode

The user has the option at boot time to put the computer into a mode of operation called Target Disk Mode (TDM).

When the Mac mini is in Target Disk Mode and connected to another Macintosh computer by a FireWire cable, the Mac mini operates like a FireWire mass storage device with the SBP-2 (Serial Bus Protocol) standard. Target Disk Mode has two primary uses:

- high-speed data transfer between computers
- diagnosis and repair of a corrupted internal hard drive

The Mac mini can operate in Target Disk Mode as long as the other computer has a FireWire port and either Mac OS X (any version) or Mac OS 9 with FireWire software version 2.3.3 or later.

To put the Mac mini into Target Disk Mode, restart the Mac mini and hold down the T key until the FireWire icon appears on the display. Then connect a FireWire cable from the Mac mini to the other computer. When the other computer completes the FireWire connection, a hard disk icon appears on its desktop.

If the FireWire cable is disconnected or the Mac mini is turned off while in Target Disk Mode, an alert appears on the other computer.

To take the Mac mini out of Target Disk Mode, drag the hard-disk icon on the other computer to the trash, then press the power button on the Mac mini.

Ethernet Port

The Mac mini has a built-in 10/100 Mbps Ethernet port. The user can connect it to either a 10Base-T or a 100Base-T hub; the port will automatically sense which type of hub is connected.

The connector for the Ethernet port is an RJ-45 connector located on the I/O panel. [Table 3-3](#) (page 25) shows the signals and pin assignments on the connector.

Table 3-3 Signals on the Ethernet connector

Pin	Signal name	Signal definition
1	TXP	Transmit (positive lead)
2	TXN	Transmit (negative lead)
3	RXP	Receive (positive lead)
4	–	Not used
5	–	Not used
6	RXN	Receive (negative lead)
7	–	Not used
8	–	Not used

The Ethernet interface in the Mac mini conforms to the ISO/IEC 802.3 specification, where applicable.

Internal Modem

Except for the education configurations, the Mac mini has an internal, fax modem. The telephone connector for the modem is an RJ-11 connector on the I/O panel. A telephone cable is included with the computer.

The internal modem has the following features:

- modem bit rates up to 56 Kbps (supports V.92 and K56 flex modem standards)
- Group 3 fax modem bit rates up to 14.4 Kbps

The internal modem is an I2S device that responds to typical AT commands. The modem delivers audio to the host where it is converted to analog for call progress monitoring. The modem also supports the “Wake up on Ring” feature.

AirPort Extreme Card

The Mac mini supports the AirPort Extreme Card, an internal wireless LAN module connected to the PCI bus. The AirPort Extreme Card is available as a build-to-order option or as an Apple Authorized Service Provider upgrade.

By communicating wirelessly with a base station, the AirPort Extreme Card can be used for Internet access, email access, and file exchange. A base station provides the connection to the Internet or the bridge between the wireless signals and a wired LAN or both. The AirPort Extreme Base Station has connectors for a wired LAN or WAN, a DSL or cable modem, and a standard telephone line using the built-in 56 Kbps modem that is available on some base station configurations.

AirPort Extreme transmits and receives data at speeds up to 54 Mbps, comparable to wired networking speeds. AirPort Extreme is compatible with earlier AirPort systems as well as other devices that conform to the IEEE 802.11b and 802.11g standards, including PCs. For more information about Wi-Fi and compatibility, see the reference at [“Wireless Networks”](#) (page 41).

Note: As is the case with the existing IEEE 802.11b standard, actual data throughput speeds will be lower than the indicated maximum connection speeds. Inherent in wireless LAN systems, bandwidth overhead is required for wireless routing, scrambling, security error correction, and other processes.

Data Security

AirPort Extreme has several features designed to maintain the security of the user’s data:

- In 802.11b mode, the system uses direct-sequence spread-spectrum (DSSS) technology that uses a multi-bit spreading code that effectively scrambles the data for any receiver that lacks the corresponding code.
- The system can use an Access Control List of authentic network client ID values (wireless and MAC addresses) to verify each client’s identity before granting access to the network.

- When communicating with a base station, AirPort Extreme uses 64-bit and 128-bit WEP encryption and WPA personal and enterprise modes to encode data while it is in transit. Additional security features may be available via firmware upgrades as 802.11 enhancements are ratified by IEEE.
- The AirPort Extreme Base Station can be configured to use NAT (Network Address Translation), protecting data from Internet hackers.
- The AirPort Extreme Base Station can authenticate users by their unique Ethernet IDs, preventing unauthorized computers from logging into your network. Network administrators can take advantage of RADIUS compatibility, used for authenticating users over a remote server. Smaller networks can offer the same security using a local look-up table located within the base station.

As an additional data security measure, VPN can be used in conjunction with the AirPort Extreme data security.

AirPort Extreme Hardware

The AirPort Extreme Card is a wireless LAN module compliant with the IEEE specification of the 802.11g standard using both OFDM (orthogonal frequency-division multiplexing) and DSSS technologies. Using DSSS, AirPort Extreme is interoperable with PC-compatible wireless LANs that conform to the 802.11b standard at speeds of 11 Mbps, 5.5 Mbps, 2 Mbps, and 1 Mbps. Using OFDM, AirPort Extreme is compatible with all 802.11g standard speeds.

When the AirPort Extreme option is installed, the antenna is located in the computer's internal frame.

AirPort Extreme Software

Software that is provided with the AirPort Extreme Card includes:

- AirPort Extreme Setup Assistant, an easy-to-use program that guides users through the steps necessary to set up AirPort Extreme or set up an AirPort Extreme Base Station.
- Users can switch between wireless networks and can create and join peer-to-peer networks. These functions are accessed via the AirPort Extreme status menu.
- AirPort Extreme Admin Utility, a utility for advanced users and system administrators. With it the user can edit the administrative and advanced settings needed for some advanced configurations.

Bluetooth Technology

Available as a fully-integrated, build-to-order option, Bluetooth is an open specification that enables short-range wireless connections between desktop and laptop computers and a host of other peripheral devices. Bluetooth support is built into Mac OS X and compliant with Bluetooth specification v1.1. It operates on a globally available 2.4 GHz frequency band (ISM band) for worldwide compatibility and has a maximum throughput of 3 Mbps.

The Bluetooth technology supports the following profiles:

- serial port (SPP) — provides a wireless serial connection to other Bluetooth devices
- dial-up networking (DUN) — enables a mobile phone to act as a modem

- object push (OPP) — enables the transfer of files between Bluetooth devices
- human interface device (HID) — enables the use of Bluetooth input devices (keyboards and mice)
- Bluetooth file transfer profile (FTP) — enables browsing of the file system of other Bluetooth devices which support Bluetooth FTP
- hardcopy cable replacement profiler (HCRP) — describes how to send rendered data over a Bluetooth link to a device, such as a printer. Although other profiles can be used for printing, the HCRP is specially designed to support hardcopy applications.
- headset profile (HSP) — enables the use of Bluetooth-enabled wireless headsets for applications such as iChat. This profile does not enable use of Apple Speech Recognition due to the fact that it is a low-precision audio channel.

Bluetooth is available as a build-to-order option or as an Apple Authorized Service Provider upgrade, which is installed as a fully integrated module. Accessing the Bluetooth capabilities without purchasing the integrated module will require a third-party USB device.

When the Bluetooth option is installed, the antenna is located in the computer's internal frame.

For more information on Bluetooth technology, refer to ["Bluetooth"](#) (page 41).

Hard Disk Drive

The Mac mini has an internal hard disk drive storage capacity of 40 GB or 80 GB with a build-to-order option of 80 GB. The internal hard disk drive operates at ATA-100 and conforms to the ATA/ATAPI-6 standard. It is set as device 0 on the host's ATA port.

The software that supports the internal hard disk is similar to that in previous Macintosh models and includes DMA support. To obtain information about that software and about the ANSI standard for the Ultra DMA ATA interface, see ["ATA Devices"](#) (page 39).

Combo Drive

The Mac mini has a slot-loading combination DVD-ROM and CD-RW drive. The Combo drive reads and writes CD media and reads DVD media as shown in [Table 3-4](#) (page 28).

Table 3-4 Types of media read and written by the Combo drive

Media type	Reading speed	Writing speed
DVD-ROM	8x (CAV)	–
DVD-R	8x max (CAV)	–
CD-R	24x (CAV)	24x max
CD-RW	24x (CAV)	16x (CLV)

Media type	Reading speed	Writing speed
CD-ROM	24x (CAV)	–

Digital audio signals from the Combo drive can be played through the sound outputs under the control of System Preferences.

The Combo drive is cable-select as device 1 on the ATA port. The device is capable of Multiword DMA Mode 2, which is a maximum of 16 megabytes per second. This interface is compatible with ANSI-NCITS industry standard ATA/ATAPI-6.

SuperDrive

The Mac mini is available with an optional slot-loading SuperDrive. The drive can read and write CD and DVD media as shown in [Table 3-5](#) (page 29).

Table 3-5 Types of media read and written by the SuperDrive

Media type	Reading speed	Writing speed
DVD-R	6x max	4x
DVD+R	6x max	4x
DVD-ROM	8x max (single layer), 6x max (dual layer)	–
DVD-RW	4x max	2x
DVD+RW	8x max	2.4x
CD-R	24x max	16x (ZCLV)
CD-RW	24x max	8x
CD-ROM	24x max	–

Digital audio signals from the SuperDrive can be played through the sound outputs under the control of System Preferences.

The SuperDrive is cable-select as device 1 on the ATA port. The device is capable of Multiword DMA Mode 2, which is a maximum of 16 megabytes per second. This interface is compatible with ANSI-NCITS industry standard ATA/ATAPI-6.

DVI Port

The Mac mini has a DVI-I (DVI with analog) port. [Figure 3-3](#) (page 30) shows the contact configuration for the DVI connector. [Table 3-6](#) (page 30) lists the signals and pin assignments.

Note: The Mac mini includes a DVI to VGA adapter.

Figure 3-3 DVI connector

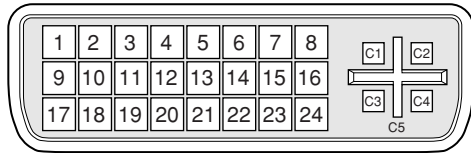

Table 3-6 Signals on the DVI connector

Pin	Signal name	Pin	Signal name
1	TMDS Data2-	13	TMDS Data3+
2	TMDS Data2+	14	+5V Power
3	TMDS Data2/4 Shield	15	Ground for +5V Power
4	TMDS Data4-	16	Hot Plug Detect
5	TMDS Data4+	17	TMDS Data0-
6	DDC Clock	18	TMDS Data0+
7	DDC Data	19	TMDS Data0/5 Shield
8	Analog vertical sync	20	TMDS Data5-
9	TMDS Data1-	21	TMDS Data5+
10	TMDS Data1+	22	TMDS Clock Shield
11	TMDS Data1/3 Shield	23	TMDS Clock+
12	TMDS Data3-	24	TMDS Clock-
C1	Analog red	C4	Analog horizontal sync
C2	Analog green	C5	Analog ground (analog R, G, B return)
C3	Analog blue		

The graphics data sent to the digital monitor use transition minimized differential signaling (TMDS). TMDS uses an encoding algorithm to convert bytes of graphics data into characters that are transition-minimized to reduce EMI with copper cables and DC balanced for transmission over fiber optic cables. The TMDS algorithm also provides robust clock recovery for greater skew tolerance with longer cables or low-cost short cables.

The Mac mini supports DVI video output for digital resolutions up to 1920x1200 with a maximum pixel clock of 154MHz coherent TMDS or 135MHz non-coherent TMDS. The Mac mini fully supports both the 23-inch Apple Cinema HD display and 20-inch Apple Cinema display.

For information about TMDS, see the reference listed in “[Digital Visual Interface](#)” (page 40).

DVI to Video Adapter

The Mac mini supports an optional DVI to S-video/composite adapter that provides S-video and composite output to an NTSC or PAL (default is NTSC) video monitor or VCR. When a display is connected by way of the video adapter, the computer detects the type of adapter and enables the composite and S-video outputs. The settings for the resolutions and standards (NTSC or PAL) are then selectable in the System Preferences Displays pane.

Note: The DVI to video adapter does not come packaged with the Mac mini and must be purchased separately.

The video output connector is a 7-pin S-video connector. [Figure 3-4](#) (page 31) shows the arrangement of the pins and [Table 3-7](#) (page 31) shows the pin assignments on the composite out and S-video connector.

Figure 3-4 S-video connector

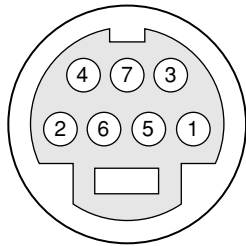

Table 3-7 Pin assignments for the S-video output connector

Pin number	S-video output connector
1	Analog GND
2	Analog GND
3	Video Y (luminance)
4	Video C (chroma)
5	composite video
6	Unused
7	Unused

The Mac mini provides video output at desktop sizes and frame rates compatible with the NTSC and PAL standards; the desktop sizes are listed in [Table 3-8](#) (page 32). Those desktop sizes produce under-scanned displays on standard monitors.

Table 3-8 Desktop sizes for S-video output

Picture size	Pixel depth
800 by 600	24 bpp
832 by 624	24 bpp
1024 by 768	24 bpp
856 by 480 widescreen (NTSC)	24 bpp
1024 by 576 widescreen (PAL)	24 bpp

Sound System

The sound system provides output through the built-in speaker and the headphone/audio line-out jack.

Note: The Mac mini also supports speakers and microphones that connect to the USB or FireWire port.

To maintain the highest level of fidelity, all signals within the computer, including audio CD playback, are maintained in digital form before being sent to the internal speaker or the headphone jack.

The sound system's input, output, and CODEC are described in the following pages.

Sound Input

The sound system accepts inputs from the following sources:

- sound from USB audio devices
- sound from FireWire audio devices

Sound Output

The computer sends analog audio signals to the following destinations:

- built-in speaker
- headphone/line-out jack
- USB audio devices
- FireWire audio devices

The computer can send digital audio data to the following destinations:

- USB audio device

- FireWire audio device

Internal Speaker

The computer integrates an internal monoral speaker. The internal speaker is muted under the following conditions:

- when headphones/line-out port is in use
- another device is selected for sound output in the Sound Preferences Output pane
- during sleep mode

Note: The system boot beep is emitted only from the internal speaker, regardless of attached external speakers.

The speaker subsystem has the following electrical characteristics:

- output power: 0.5 Wrms
- frequency response: 400 Hz to 15 kHz +/-3db

Headphone and Line-out Jack

The headphone/line-out jack is located on the I/O panel on the rear of the computer.

The headphone/line-out jack has the following electrical characteristics:

- output level: 1.42Vrms / +5dbu
- frequency response: 20Hz to 20KHz, +/-0.5db
- S/N ratio: >90 db unweighted
- distortion: <0.005%
- output power: 40 mW per channel into 32 ohms
- channel separation: >70 db at 1 kHz, 1 mW
- output impedance: 10 ohms

The minimum recommended headphone impedance is 32 ohms. Headphones with an impedance lower than 32 ohms may experience a higher level of distortion.

Audio CODEC

The audio CODEC in the Mac mini has the following specifications:

- 24-bit, 32 to 96 kHz D/A converter
- filtered analog line-level output
- I2S digital audio interface

RAM Expansion

This chapter describes the RAM expansion modules supported by Mac mini.

RAM Expansion

The Mac mini has one RAM expansion slot that accepts standard DDR333 PC2700, 184-pin DIMMs (dual inline memory modules) for use with SDRAM devices. The Mac mini supports DIMM sizes 256 MB, 512 MB, or 1 GB of memory for a total system maximum of up to 1 GB.

Note: Additional memory can be installed only by Authorized Apple Service Providers. Contact your Apple Care representative for installing additional RAM.

RAM Expansion Modules

The RAM expansion modules for the Mac mini are 184-pin SDRAM DIMMs that are 2.5 volt, unbuffered, 8-byte, non-parity, and PC2700 compliant. The speed of the SDRAM devices must be rated at 167 MHz or faster.

Important: RAM expansion DIMMs for the Mac mini must use DDR SDRAM devices. If the user installs a DIMM that uses EDO or SGRAM devices, the computer will beep several times when the user attempts to restart the computer.

Mechanical Design of RAM DIMMs

The mechanical characteristics of the RAM expansion DIMM are given in the JEDEC specification for the 184-pin 8-byte DRAM DIMM. The specification number is JEDEC MO-161-D. To obtain a copy, see the reference information at [“RAM Expansion Modules”](#) (page 39).

The maximum height of DIMMs for use in the Mac mini is 1.50 inches.

Electrical Design of RAM DIMMs

The electrical characteristics of the RAM DIMM are given in section 4.5.6 of the JEDEC Standard 21-C. The specification is available from the Electronics Industry Association's website. The specification defines several attributes of the DIMM, including storage capacity and configuration, connector pin assignments, and electrical loading. To obtain a copy, see the reference information at [“RAM Expansion Modules”](#) (page 39).

The presence detect serial EEPROM specified in the JEDEC standard is required and must be set to properly define the DIMM configuration. Details about the required values to be stored in the presence detect EEPROM can be found in sections 4.5.4 and 4.1.2.5 of the JEDEC standard 21-C specification.

The RAM DIMMs are required to be PC2700 compliant. To obtain information about the PC2700 specification, see the reference information at “[RAM Expansion Modules](#)” (page 39).

The SDRAM devices used in the RAM expansion modules must be self-refresh type devices for operation from a 2.5 V power supply.

DIMM Configurations

The largest DIMM supported is a two-bank DIMM of 1 GB using 512 Mbit using SDRAM devices. The largest bank size supported by the memory controller is 512 MB. The maximum number of devices per DIMM is 16. CAS latency is 2.5.

[Table 4-1](#) (page 36) shows information about the different sizes of SDRAM devices used in the memory modules.

Table 4-1 Sizes of DDR SDRAM expansion DIMMS and devices

Size of DIMM	SDRAM device size	Device configuration	Devices per bank	number of banks
256 MB	256 Mbits	8 M x 8 x 4	8	1
512 MB	256 Mbits	8 M x 8 x 4	8	2
512 MB	512 Mbits	16 M x 8 x 4	8	1
1 GB	512 Mbits	16 M x 8 x 4	8	2

The Mac mini accepts only one DIMM. Any of the supported DIMM sizes can be installed in the slot.

RAM Addressing

Signals A[0] – A[12] and BA[0] – BA[1] on each RAM DIMM make up a 15-bit multiplexed address bus that can support several different types of SDRAM devices.

Supplemental Reference Documents

For more information about the technologies mentioned in this developer note, consult the following references.

For information about older models of Macintosh computers, refer to the developer notes archive at

<http://developer.apple.com/documentation/Hardware/hardware2.html>

Apple Technical Notes

Apple Technical Notes answer many specific questions about the operation of Macintosh computers and the Mac OS. The Technical Notes are available on the Technical Note website at

<http://developer.apple.com/technotes/>

3D Graphics

Developers of 3D graphics for games should know about OpenGL for Macintosh[®], a version of SGI's application programming interface (API) and software library for 3D graphics.

Developer support and documentation is available at

<http://developer.apple.com/opengl/>

PowerPC G4 Microprocessor

Information about the PowerPC G4 microprocessor is available on the World Wide Web at

http://e-www.motorola.com/webapp/sps/site/prod_summary.jsp?code=MPC7457&nodeId=018rH3bTdG8653

Velocity Engine (AltiVec)

Velocity Engine is Apple's name for the AltiVec vector processor in the PowerPC G4 microprocessor. Apple provides support for developers who use the Velocity Engine in their applications. Documentation, development tools, and sample code are available on the World Wide Web, at

<http://developer.apple.com/hardwaredrivers/ve/index.html>

AltiVec Technology Programming Environments Manual (AltiVec PEM) is a reference guide for programmers. It contains a description for each instruction and information to help in understanding how the instruction works. Obtain a copy of the AltiVec PEM through the Motorola AltiVec site on the World Wide Web, at

<http://www.freescale.com/webapp/sps/site/overview.jsp?nodeId=02VS0I81285Nf2>

Mac OS X

For information about Mac OS X, see Apple's developer website at

<http://developer.apple.com/documentation/MacOSX/index.html>

O'Reilly & Associates publishes a series of books about Mac OS X development. The books in this series have been technically reviewed by Apple engineers and are recommended by the Apple Developer Connection.

I/O Kit

The I/O Kit is part of Darwin, the operating system foundation for Mac OS X. The documentation for I/O Kit is available on Apple's Darwin website at

<http://developer.apple.com/documentation/Darwin/Darwin.html/>

Open Firmware

The software firmware implemented on current Macintosh computers follows the standard defined by the Open Firmware IEEE 1274-1994 specification. Three Technical Notes provide an introduction to Open Firmware on the Macintosh platform. They are:

TN1061: Open Firmware, Part I, available at

<http://developer.apple.com/technotes/tn/tn1061.html>

TN1062: Open Firmware, Part II, available at

<http://developer.apple.com/technotes/tn/tn1062.html>

TN1044: Open Firmware, Part III, available at

<http://developer.apple.com/technotes/tn/tn1044.html>

Other Technical Notes provide additional information about Open Firmware on the Macintosh.

TN2000: PCI Expansion ROMs and You, at

<http://developer.apple.com/technotes/tn/tn2000.html>

TN2001: Running Files from a Hard Drive in Open Firmware, at

<http://developer.apple.com/technotes/tn/tn2001.html>

TN2004: Debugging Open Firmware Using Telnet, available at

<http://developer.apple.com/technotes/tn/tn2004.html>

RAM Expansion Modules

The mechanical characteristics of the DIMM are given in the JEDEC specification number JESD-95. The specification can be found by using the search string JESD-95 on the Electronics Industry Association's website at

<http://www.jedec.org/DOWNLOAD/default.cfm>

The electrical characteristics of the DIMM and the SO-DIMM are given in JEDEC Standard 21-C, release 7 (JESD-21C). The specification can be found by using the search string JESD21-C on the Electronics Industry Association's website at

<http://www.jedec.org/DOWNLOAD/default.cfm>

ATA Devices

ATA (AT Attachment), also referred to as integrated drive electronics (IDE), is a standard interface used with storage devices such as hard disk drives. For more information on ATA, refer to the following Apple website at

<http://developer.apple.com/documentation/Hardware/DeviceManagers/ata/ata.html>

ATA Manager 4.0 supports driver software for internal IDE drives and includes DMA support. For the latest information about ATA Manager 4.0, see Technical Note TN1098, ATA Device Software Guide Additions and Corrections, available on the world wide web at

<http://developer.apple.com/technotes/tn/tn1098.html>

The web page for Technical Note TN1098 includes a link to a downloadable copy of *ATA Device Software Guide*.

Information about the ATA standards is available at the Technical Committee T13 AT Attachment website, at

<http://www.t13.org/>

USB Interface

For more information about USB on Macintosh computers, developers should refer to Apple Computer's *Accessing Hardware from Applications*. Information is also available on the World Wide Web, at

<http://developer.apple.com/hardwaredrivers/usb/index.html>

Mac OS X includes support for a wide variety of USB classes. Detailed specifications of these classes are available at

<http://www.usb.org/developers/devclass/>

For full specifications of the Universal Serial Bus, developers should refer to the USB Implementers Forum on the World Wide Web, at

<http://www.usb.org/developers/docs>

Ethernet

For information on Ethernet specifications and design guides, go to the World Wide Web at

<http://standards.ieee.org/>

FireWire Interface

For additional information about the FireWire IEEE 1394 interface and the Apple APIs for FireWire software, refer to the resources available on the Apple FireWire website at

<http://developer.apple.com/firewire/index.html>

The IEEE 1394 standard is available from the IEEE. Ordering information can be found on the World Wide Web at

<http://shop.ieee.org/store>

Additional useful information also available at the 1394 Trade Association's website:

<http://www.1394ta.org/>

Digital Visual Interface

For information about transition minimized differential signaling (TMDS) used with digital video monitors, see the specification, Digital Visual Interface DVI Revision 1.0, available on the website of the Digital Display Working Group (DDWG) at

<http://www.ddwg.org/>

Wireless Networks

More information about Wi-Fi and wireless networks using the IEEE 802.11 standard is available on the website of the WiFi Alliance, at

<http://www.wi-fi.org/>

Bluetooth

For more information regarding Bluetooth technology, refer to the following locations on the World Wide Web.

Bluetooth specification:

<http://www.bluetooth.org/spec/>

Bluetooth SIG:

<http://www.bluetooth.org>

Bluetooth developer tools on the Apple web site at:

<http://developer.apple.com/hardwaredrivers/bluetooth>

Abbreviations

Standard units of measure used in this developer note include:

A	amperes	MB	megabytes
cm	centimeters	Mbps	megabits per second
dB	decibels	Mbit	megabits
GB	gigabytes	MHz	megahertz
Hz	hertz	mm	millimeters
KB	kilobytes	ns	nanoseconds
kg	kilograms	V	volts
kHz	kilohertz	VDC	volts direct current
mA	milliamperes		

Other abbreviations used in this note include:

\$n	hexadecimal value n
10Base-T	an Ethernet standard for data transmission at 10 Mbits per second
100Base-T	an Ethernet standard for data transmission at 100 Mbits per second
A/D	analog to digital
AGP	accelerated graphics port
ANSI	American National Standards Institute
API	application programming interface
ATA	Advanced Technology Attachment
ATAPI	ATA Packet Interface
CAS	column address strobe
CAV	constant angular velocity
CD	compact disc
CD-ROM	compact disc read-only memory

Abbreviations

CLV	constant linear velocity
CPU	central processing unit
D/A	digital to analog
DAA	data access adapter
DB-DMA	descriptor-based direct memory access
DDR	double data rate, a type of SDRAM
DIMM	Dual Inline Memory Module
DMA	direct memory access
DRAM	dynamic random-access memory
EDO	extended data out
EEPROM	electrically erasable programmable ROM
EIDE	enhanced integrated device electronics
G4	Generation 4, the fourth generation of PowerPC microprocessors, incorporating AltiVec technology
GART	graphics address remapping table
GND	ground
HCRP	hardcopy cable replacement profiler
HFS	hierarchical file system
HID	human interface device, a class of USB devices
IC	integrated circuit
IDE	integrated device electronics
IEC	International Electrotechnical Commission
IIC (I2C)	inter IC control bus
IIS (I2S)	inter IC sound bus
I/O	input and output
Intrepid	memory controller and I/O device and disk controller
ISM	industrial, scientific, and medicine
IR	infrared
ISO	International Organization for Standardization

Abbreviations

JEDEC	Joint Electron Device Engineering Council
L1	level 1 or first level
L2	level 2 or second level
LAN	local area network
LED	light emitting diode
MAC	media access controller
Mac OS	Macintosh Operating System
modem	modulator-demodulator
NMI	nonmaskable interrupt
OHCI	Open Host Controller Interface
OS	operating system
PCI	Peripheral Component Interconnect
PLL	phase-locked loop
RADIUS	Remote Authentication Dial-In User Service
RAM	random-access memory
RCA	Radio Corporation of America
rms	root mean square
ROM	read-only memory
SCSI	Small Computer System Interface
SDRAM	synchronous dynamic RAM
SGRAM	synchronous graphics RAM
SNR	signal to noise ratio
SPD	Serial Presence Detect
THD	total harmonic distortion
THD+N	total harmonic distortion plus noise
USB	Universal Serial Bus
VCC	positive supply voltage (voltage for collectors)
VPN	virtual private network

APPENDIX B

Abbreviations

Wi-Fi	wireless fidelity
ZCLV	zone constant linear velocity

Index

Numerals

3D graphics [37](#)

A

AGP bus [18](#)

AirPort Admin Utility [27](#)

AirPort Extreme [20, 26–27](#)

AirPort Extreme Application [27](#)

AirPort Extreme Base Station [26, 27](#)

AirPort Extreme Card [20, 26–27](#)

 hardware components [27](#)

 security features [26](#)

 software components [27](#)

AirPort Extreme Setup Assistant [27](#)

ATA device configuration [19](#)

ATA disk interface

 reference information for [39](#)

ATA interface [28](#)

B

block diagram [15, 16](#)

Bluetooth [41](#)

boot ROM [18](#)

booting from a FireWire device [23](#)

buses [15, 16, 17](#)

C

cache [17](#)

cache. *See* L2 cache

CD-RW/DVD-R drive [29](#)

CD-RW/DVD-ROM drive [28](#)

clock speeds [17](#)

Combo drive [28](#)

composite connector [31](#)

computer identification [13](#)

connectors

 composite/S-video [31](#)

 Ethernet [25](#)

 FireWire 400 [23](#)

 S-video/composite [31](#)

 USB [21](#)

custom ICs

 Intrepid memory and I/O controller IC [17](#)

D

DIMMs, for RAM expansion [35](#)

 electrical design of [35](#)

 JEDEC specifications [35](#)

 mechanical design of [35](#)

 specifications [39](#)

DMA support [18](#)

DVI port [29](#)

DVI-to-video adapter [31](#)

E

enclosure [12](#)

Ethernet controller [18](#)

Ethernet port [25](#)

external features [12](#)

external monitor port [29–31](#)

F

FireWire 400 connector [23](#)

FireWire 400 controller [19](#)

FireWire 400 ports [22–25](#)

FireWire interface [40](#)

FireWire port

booting from [23](#)
 FireWire ports
 Target Disk mode [24](#)

G

G4. *See* PowerPC G4 microprocessor
 graphics address remapping table (GART) [18](#)
 graphics IC [18](#)

H

hard disk drive [28](#)
 HCRP profile [28](#)
 headphone jack [33](#)
 HID profile [28](#)
 HSP profile [28](#)

I

IDE hard disk [28](#)
 input and output ports
 Ethernet [25](#)
 FireWire 400 [22](#)
 USB [21](#)
 internal modem [19](#)
 Intrepid memory and I/O controller IC [17](#)

J

JEDEC specifications for RAM DIMMs [35](#)

L

L2 cache [17](#)

M

microprocessor [17, 37](#)
 microprocessor clock speeds [17](#)
 modem [19, 26](#)

N

new features [11](#)
 NMI [13](#)
 non-maskable interrupt [13](#)

O

OHCI controller for USB [22](#)
 Open Firmware [38](#)
 reference information for [38](#)

P

power controller IC [19](#)
 power saving modes [19](#)
 PowerPC G4 microprocessor [17, 37](#)
 programmer's switch [13](#)

R

RAM DIMMs. *See* DIMMs
 RAM expansion [35–36](#)
 RAM Expansion Modules. *See* DIMMs
 RAM expansion slots [35](#)
 ROM. *See* boot ROM

S

S-video connector [31](#)
 sound circuitry [20](#)
 sound system [20, 32–33](#)
 input sources [32](#)
 output devices [32](#)
 headphone jack [33](#)
 internal speakers [33](#)
 speakers [33](#)
 system software [13–14](#)

T

Target Disk Mode [24](#)
 TV display adapter [31](#)

U

- USB controller IC [20](#)
- USB features [22](#)
- USB interface [39](#)
- USB ports [21–22](#)
 - booting from [22](#)
 - connectors [21](#)
 - controller type [22](#)
 - data transfer speeds [22](#)
 - suspend mode [22](#)
 - wakeup from Sleep mode [22](#)
- USB suspend mode [20](#)

V

- Velocity Engine [14](#)
- video display [29](#)
 - controller IC [18](#)
 - subsystem architecture [18](#)
- video port. *See* external monitor port

W

- wireless LAN module [20, 26–27](#)
 - base station [26](#)
 - hardware components [27](#)
 - security features [26](#)
 - software components [27](#)